

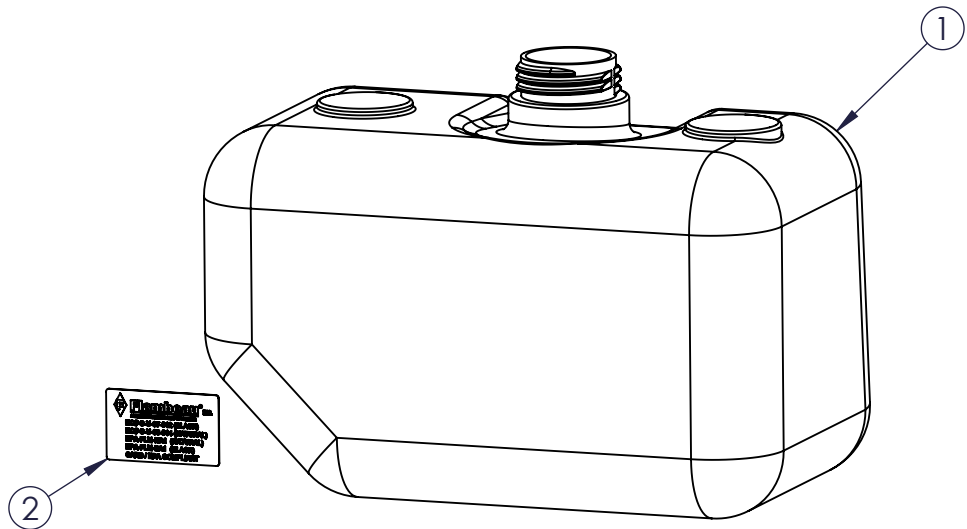

REVISIONS					
REV	ECR	DESCRIPTION	DATE	BY	APR
A	NPN	RELEASED FOR PRODUCTION	10-22-14	ANA	SAB

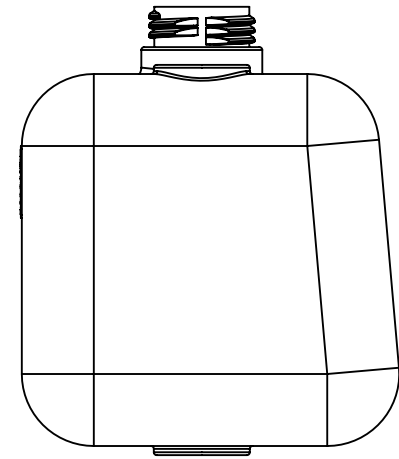
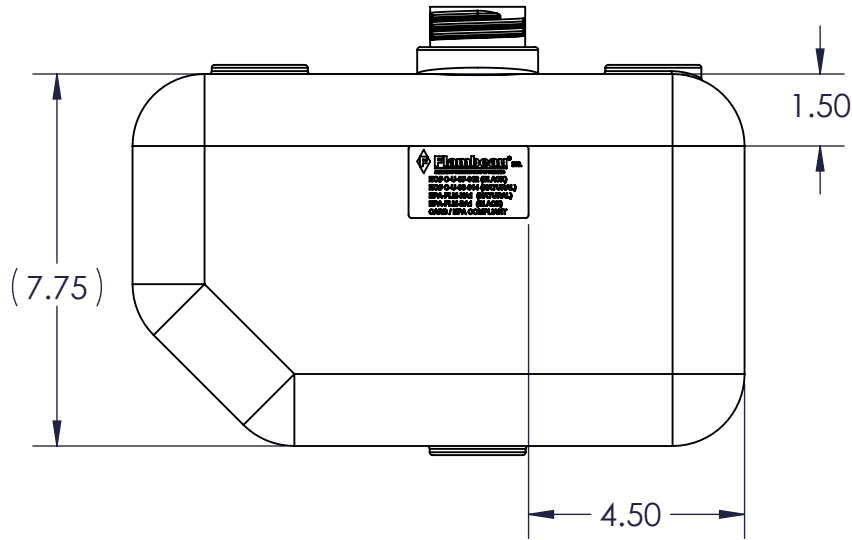
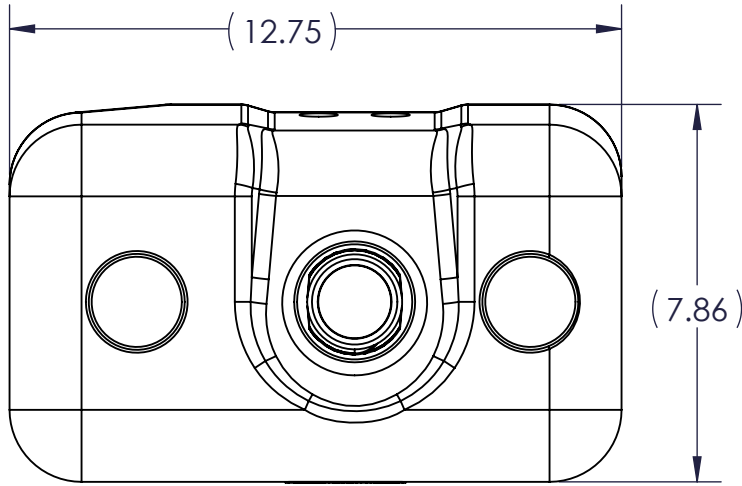

ITEM	FPN	DWG #	DESCRIPTION	QTY
2	477026x	477026	CARB/EPA FUEL TANK LABEL	1
1	070655B-FL	4443-2	2.5 GALLON TANK, CARB, BLACK	1

<b>PROPRIETARY AND CONFIDENTIAL</b> THE INFORMATION CONTAINED IN THIS DRAWING IS THE SOLE PROPERTY OF FLAMBEAU, INC. ANY REPRODUCTION IN PART OR AS A WHOLE WITHOUT THE WRITTEN PERMISSION OF FLAMBEAU, INC. IS PROHIBITED.  <b>DIMENSIONS ARE IN INCHES.</b> THE FOLLOWING TOLERANCES APPLY UNLESS OTHERWISE SPECIFIED ANGULAR: ±3° TWO PLACE x.xx ±.125" THREE PLACE x.xxx ±.060" DIMENSIONS IN PARENTHESIS ( ) ARE FOR REFERENCE ONLY.	SHT	 <b>FLAMBEAU, INC.</b>		
	1	SCALE: 1:4	BFI NO: NA	DRAWN BY: ANA DATE: 10-21-14
	OF	MOLD NO: 4443	MAT'L: NA	FPN: 071402AE
	1	DESCRIPTION: 2.5 GALLON EPA/CARB FUEL TANK ASSEMBLY		
		CUSTOMER: US PLASTICS		DWG NO: 071402

<b>CUSTOMER SIGN-OFF</b>
COMPANY:
SIGNATURE:
PRINTED NAME:
DATE: