

SEE DRAWING NUMBER
#970103 FOR HANDLE
SPECIFICATIONS

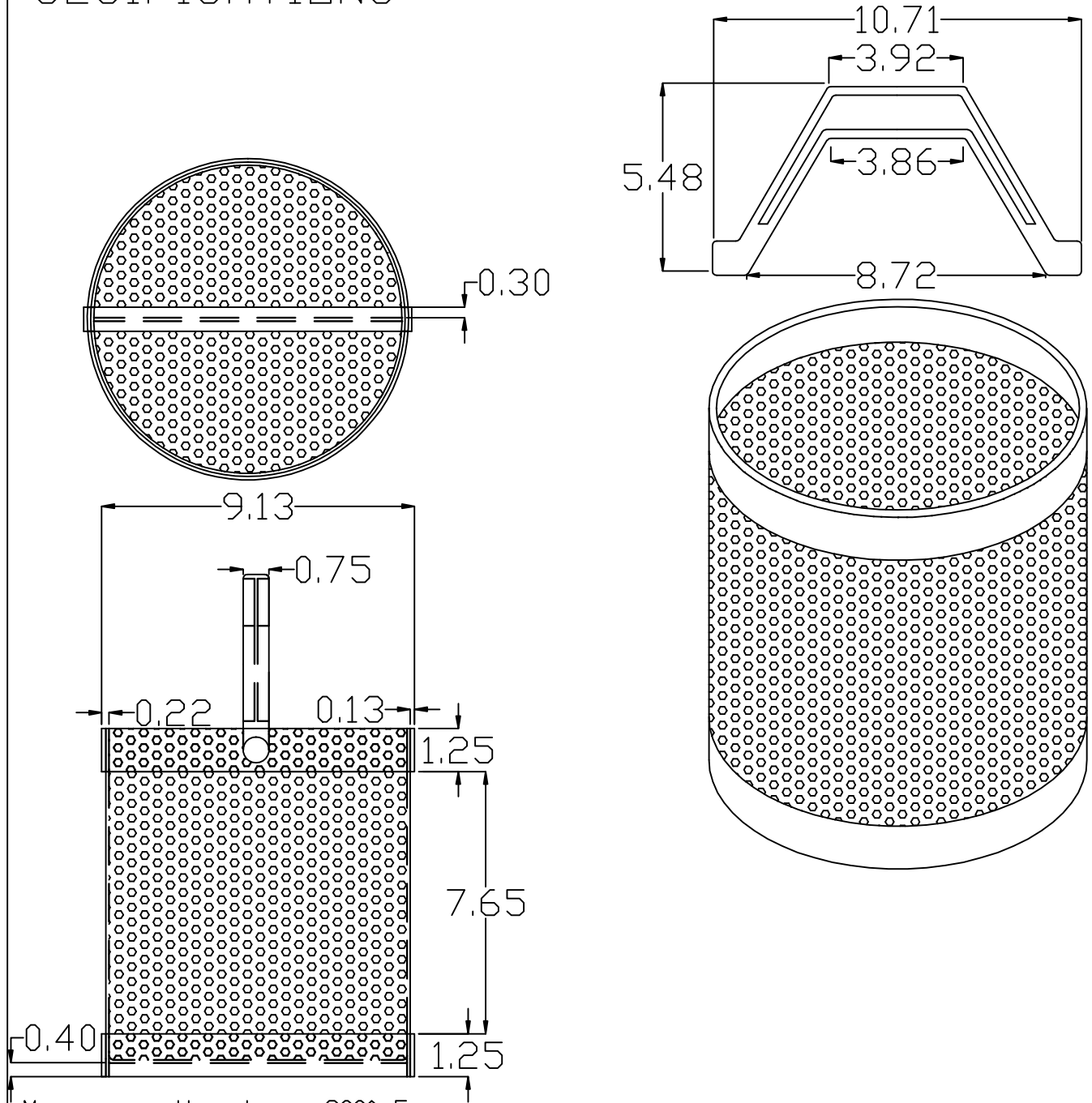

Max. operating temp. 200° F.

See chemical resistance
chart for compatibility.

DIMENSIONS ARE IN INCHES
TOLERANCES:
FRACTIONAL ± 1/8
ANGULAR: MACH ± BEND ±
TWO PLACE DECIMAL ±
THREE PLACE DECIMAL ±

	NAME	DATE
DRAWN	TNH	12/19/07
CHECKED		
ENG APPR.		
MFG APPR.		
Q.A.		

COMMENTS:
3/32 PERFORATION
NOT ACTUAL
SIZE

PROPRIETARY AND CONFIDENTIAL
THE INFORMATION CONTAINED IN THIS
DRAWING IS THE SOLE PROPERTY OF
TAMCO. ANY REPRODUCTION IN PART
OR AS A WHOLE WITHOUT THE
WRITTEN PERMISSION OF TAMCO IS
PROHIBITED

MATERIAL
POLYPROPYLENE
FINISH --
DO NOT SCALE DRAWING

POLYPROPYLENE DIPPING BASKET

TAMCO INDUSTRIES
Tank Manufacturing and Fabrication

1390 Neubrecht Road
Lima, Ohio 45801

SIZE STOCK NO.	14203	REV.
A		
SCALE: none	WEIGHT:	SHEET 1 OF 1