

Catalog options:  
Cover #3007, Floating Cover #3016, Tank Stand #5060

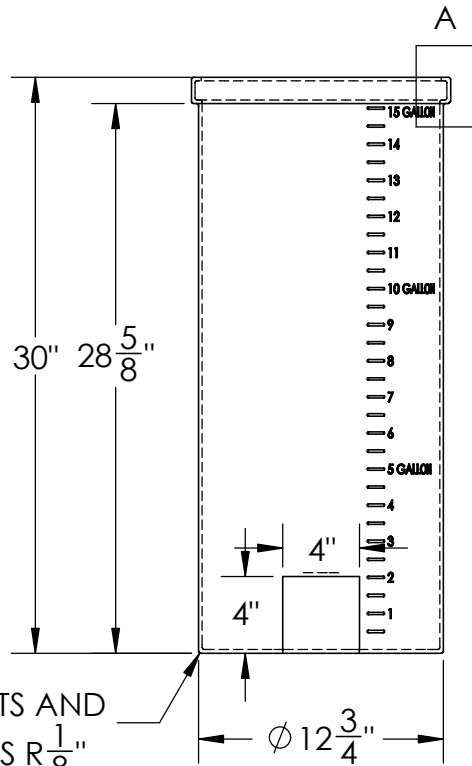

ALL FILLETS AND  
ROUNDS R $\frac{1}{8}$ "

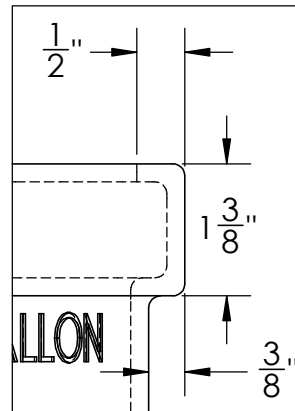

DETAIL A

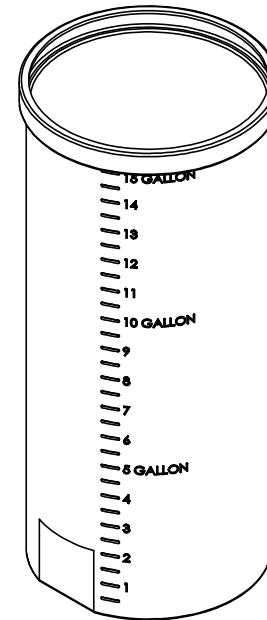

Standard Weight Polyethylene  
Storage Tank  
w/ External Flange #3481



1390 Neubrecht Road  
Lima, Ohio 45801

STOCK NO. **3481** REV **A**

DO NOT SCALE DRAWING

WEIGHT: 9 lbs.

DIMENSIONS ARE IN INCHES TOLERANCE: $\pm 1/4$ "		NAME	DATE
MATERIAL	LLDPE - FDA resin	DRAWN	CDH 11/15/16
CAPACITY	15 US gal.	APPROVED	BAT 11/15/16
GRADUATIONS	1/2 gal.	COMMENTS:  Translucent UV Stabilized	
NOMINAL WALL THICKNESS	3/16"		

**PROPRIETARY AND CONFIDENTIAL**  
THE INFORMATION CONTAINED IN THIS  
DRAWING IS THE SOLE PROPERTY OF  
TAMCO. ANY REPRODUCTION IN PART  
OR AS A WHOLE WITHOUT THE WRITTEN  
PERMISSION OF TAMCO IS PROHIBITED.

MAX. OPERATING TEMP. 140°F  
INTERMITTENT SERVICE TO 160°F  
SEE CHEMICAL RESISTANCE  
CHART FOR COMPATIBILITY