

Catalog Option:  
Tanks: #9161

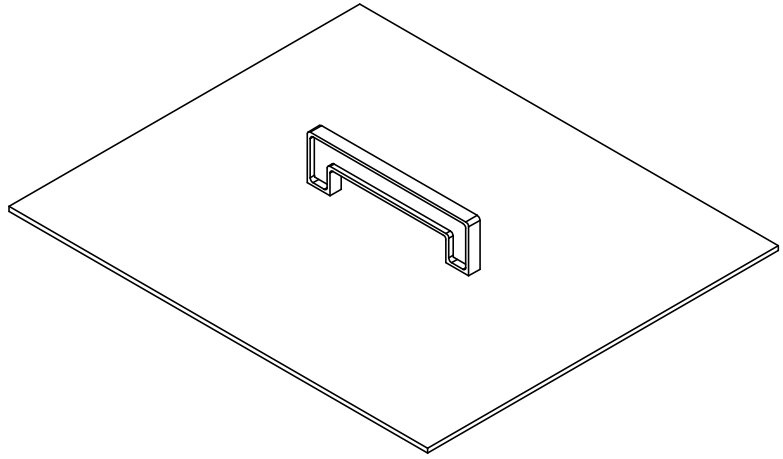

Rectangular Tank  
Cover #9191

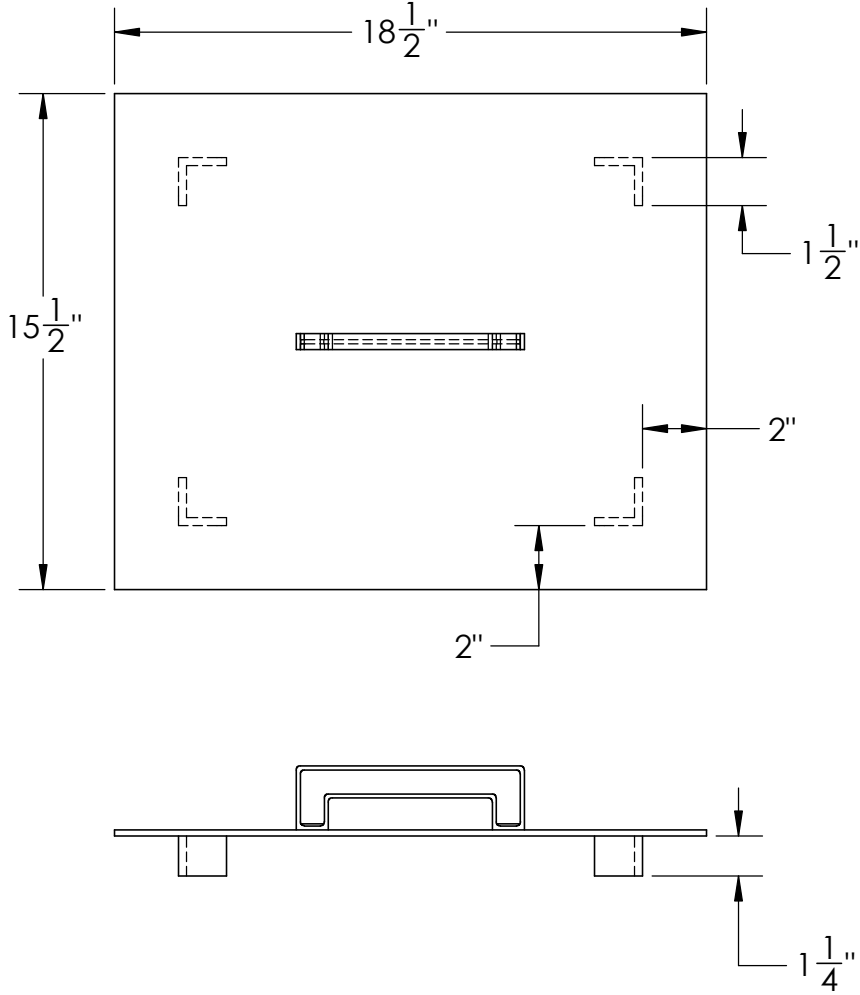

STOCK NO. **9191** REV **A**

DO NOT SCALE DRAWING WEIGHT: 2.6 lbs.

DIMENSIONS ARE IN INCHES TOLERANCE: ± 1/4"		NAME	DATE
MATERIAL POLYPROPYLENE		DRAWN CDH	07/06/16
CAPACITY N/A		APPROVED BAT	07/14/16
GRADUATIONS N/A		COMMENTS:  Welded Construction	
NOMINAL WALL THICKNESS 3/16"			

**PROPRIETARY AND CONFIDENTIAL**  
THE INFORMATION CONTAINED IN THIS DRAWING IS THE SOLE PROPERTY OF TAMCO. ANY REPRODUCTION IN PART OR AS A WHOLE WITHOUT THE WRITTEN PERMISSION OF TAMCO IS PROHIBITED.

MAX. OPERATING TEMP. 200°F  
SEE CHEMICAL RESISTANCE CHART FOR COMPATABILITY