

Copyright. All information furnished within this document, electronic file or design correspondence is the property of Den Hartog industries, Inc. and shall not be used, disclosed to others or copied without the expressed written consent of Den Hartog Industries, Inc.

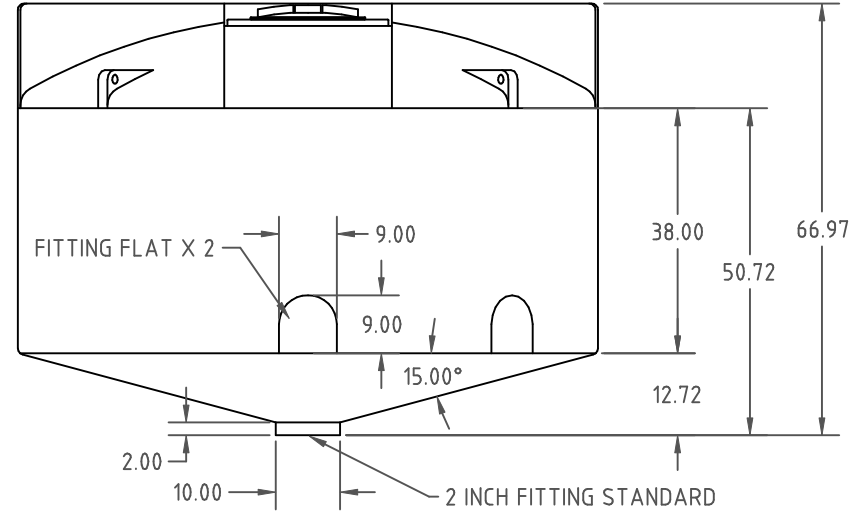

				DRAWN / DATE DHJ 1/7/11	MATERIAL 10420
				APPRD. / DATE REH 2/2/11	
REV	DESCRIPTION	BY / DATE	CCN		
ALL DIMENSIONS ARE IN DECIMAL INCHES TOLERANCES UNLESS OTHERWISE SPECIFIED				SHOT WEIGHT: 240 LBS.	NOTES: 1. THICKNESS @ BOTTOM SIDE WALL .200
POLYETHYLENE				SHIPPING WEIGHT: 242 LBS.	
±1% @ 68° F				FINISH:	
METAL DECIMAL ± .125" FRACTION ± 1/4" ANGLE ± 1°				THIRD ANGLE PROJECTION ANSI 14.5M	

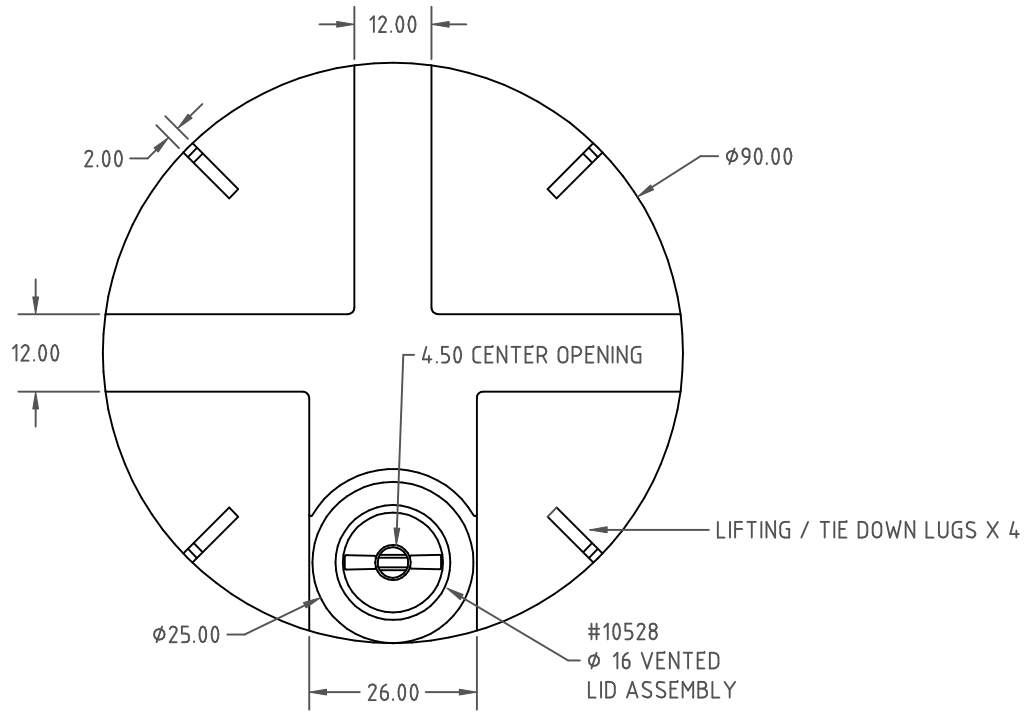

Den Hartog

INDUSTRIES, INC.

Ace Roto-Mold Injection Molding Blow Molding Sow Joy

4010 HOSPERS DRIVE S. BOX 425, HOSPERS, IOWA 51238-0425

DESCRIPTION 1150 GALLON 90" DIA. X 15° CONE BOTTOM TANK W/ INDUSTRIAL TOP	
SCALE N.S.	PART NO. CB1150-90