

REVISIONS					
REV	ECR	DESCRIPTION	DATE	BY	APR
A	NPN	RELEASED FOR PRODUCTION	02-27-19	CRW	PAM

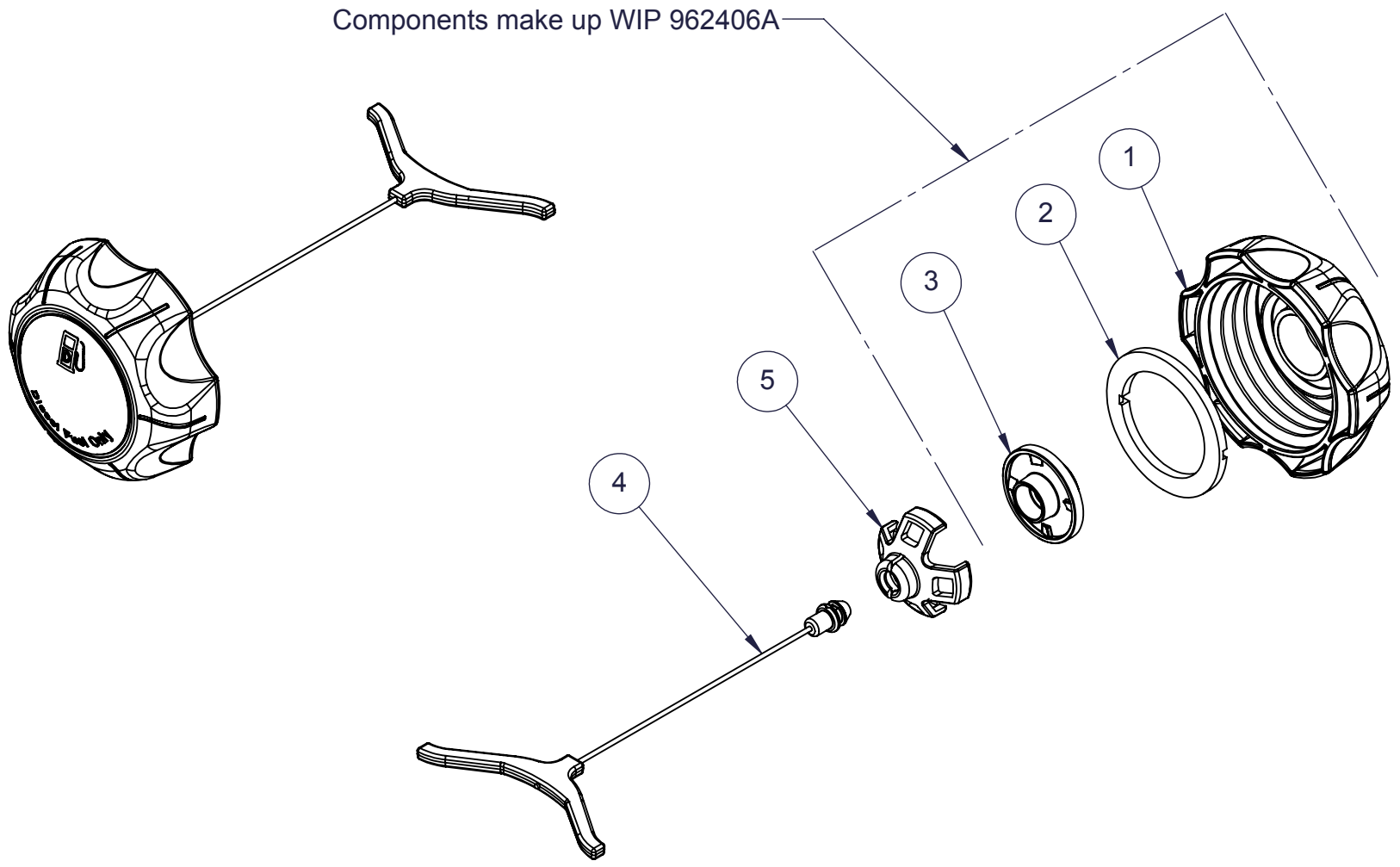
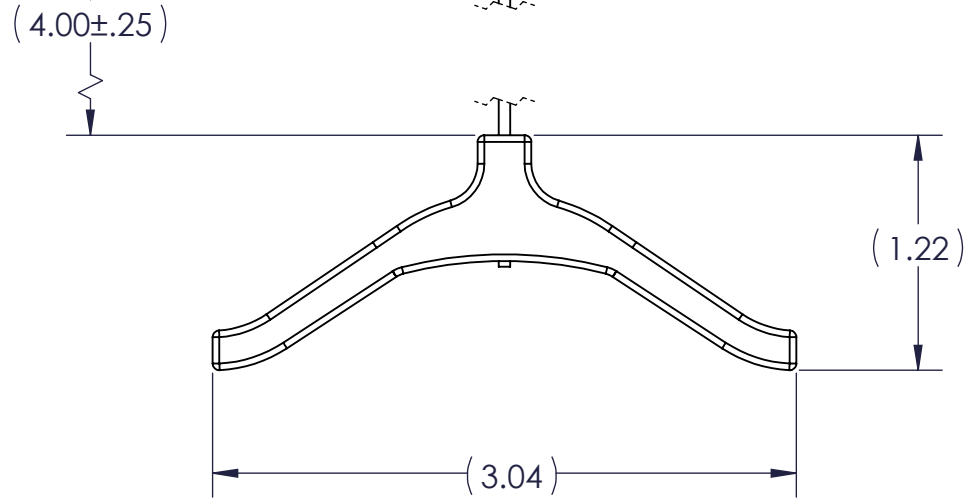
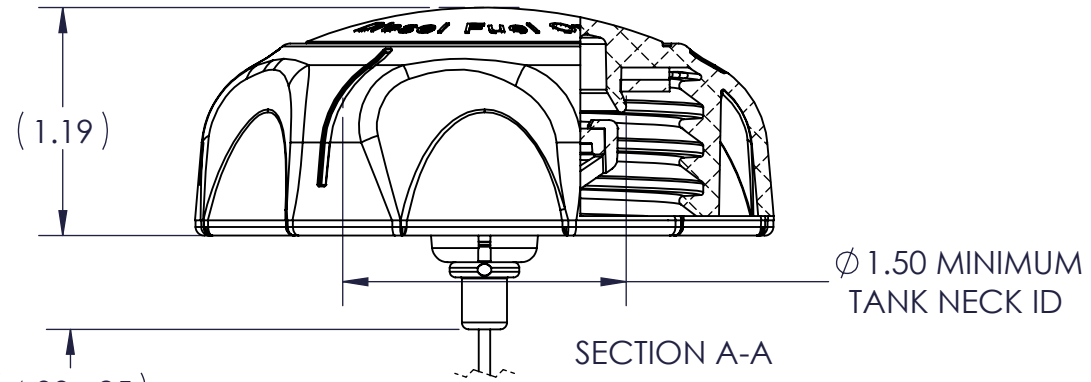
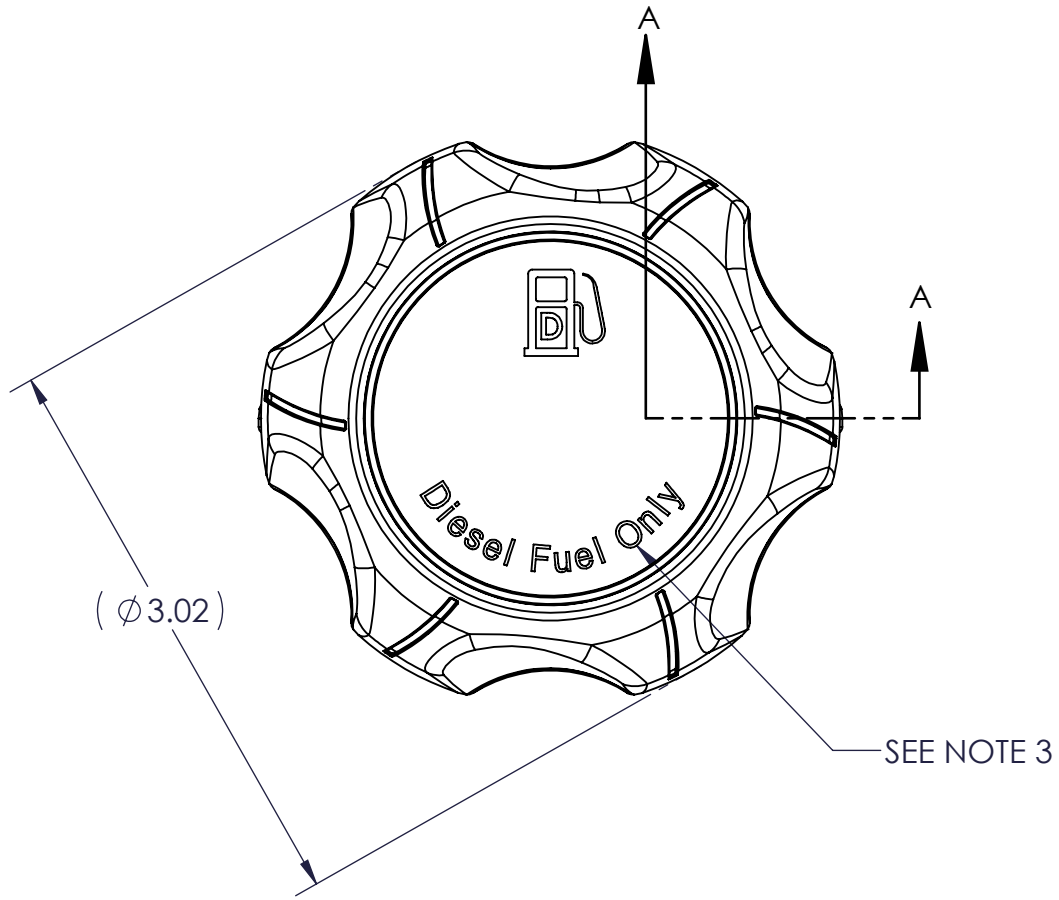

- NOTES:**
- CAP THREAD IS MODIFIED BUTTRESS THREAD 2.25" - 5 TPI
 - SEE DWG S-10307 FOR MATING THREAD SPECIFICATIONS.
 - GRAPHIC IS PRINTED BLACK DFO. REFERENCE DWG S-10032 FOR DETAILS.
 - TESTING AND VERIFICATION THAT THIS PRODUCT IS APPROPRIATE FOR THE APPLICATION FOR WHICH IT IS INTENDED IS THE SOLE RESPONSIBILITY OF THE PURCHASING PARTY.

ITEM	FPN	DWG #	DESCRIPTION	QTY
5	962300A	962300	Snap Retainer, Fluids Caps	1
4	962304A	962304	Fluids 4" Tether 2.25" EPA/CARB Caps	1
3	912497B	S-10011	RETAINER, VENTED, NYLON	1
2	468833A	468833A	GASKET	1
1	6825	S-10851	PDM-00100 2.25 Cap 6 lobe unvented	1

PROPRIETARY AND CONFIDENTIAL
THE INFORMATION CONTAINED IN THIS DRAWING IS THE SOLE PROPERTY OF FLAMBEAU, INC. ANY REPRODUCTION IN PART OR AS A WHOLE WITHOUT THE WRITTEN PERMISSION OF FLAMBEAU, INC. IS PROHIBITED.

DIMENSIONS ARE IN INCHES.
THE FOLLOWING TOLERANCES APPLY UNLESS OTHERWISE SPECIFIED:
ANGULAR: $\pm 3^\circ$
TWO PLACE x.xx $\pm .01$ "
THREE PLACE x.xxx $\pm .005$ "

SHT 1 OF 1

FLAMBEAU, INC.

Scale: 1:1 BFI No: NA Drawn By: CRW Date: 02-26-19
Mold No: 6825 Mat'l: NA FPN: 080314AE

Description: 2.25" THREAD VENT GRN DFO 4" T

Customer: Flambeau Fluid Systems Dwg No: 080314