

3/4" NPT PP
Flow Spigot #16484

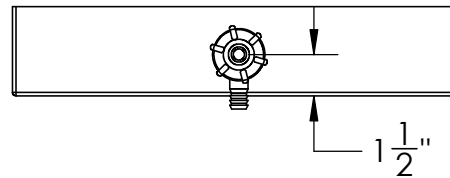

Polypropylene Tray/Tip
Plating Tank #14768

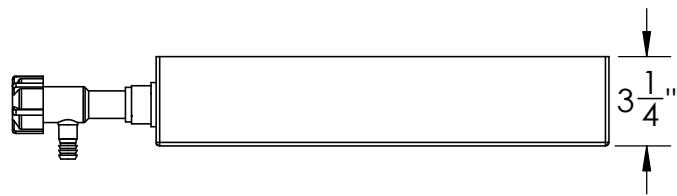
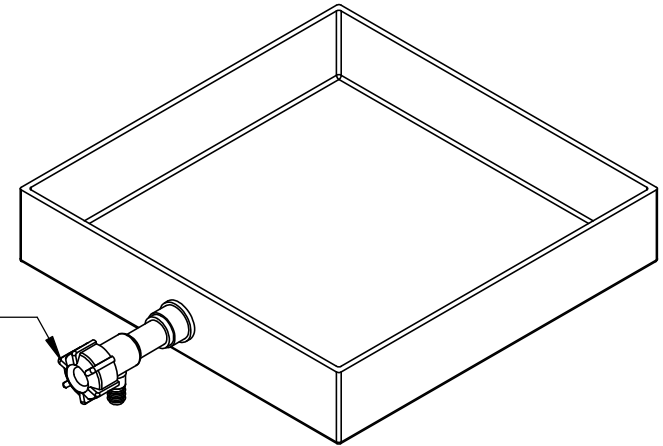

1390 Neubrecht Road
Lima, Ohio 45801

STOCK NO.

14768

REV

A

DO NOT SCALE DRAWING

WEIGHT: 4.5 lbs.

DIMENSIONS ARE IN INCHES TOLERANCE: $\pm 1/4$ "		NAME	DATE
MATERIAL	WELDED PP	DRAWN	JMP 10/25/18
CAPACITY	N/A	APPROVED	
GRADUATIONS	N/A	COMMENTS:	
NOMINAL WALL THICKNESS	1/4"	Other tray sizes, special partitions, flanges, outlets, etc. are available	

PROPRIETARY AND CONFIDENTIAL

THE INFORMATION CONTAINED IN THIS DRAWING IS THE SOLE PROPERTY OF TAMCO. ANY REPRODUCTION IN PART OR AS A WHOLE WITHOUT THE WRITTEN PERMISSION OF TAMCO IS PROHIBITED.

MAX. OPERATING TEMP. 140°F
INTERMITTENT SERVICE TO 160°F
SEE CHEMICAL RESISTANCE
CHART FOR COMPATABILITY