

FOR ADDITIONAL DETAIL,
SEE INDIVIDUAL PART DRAWINGS

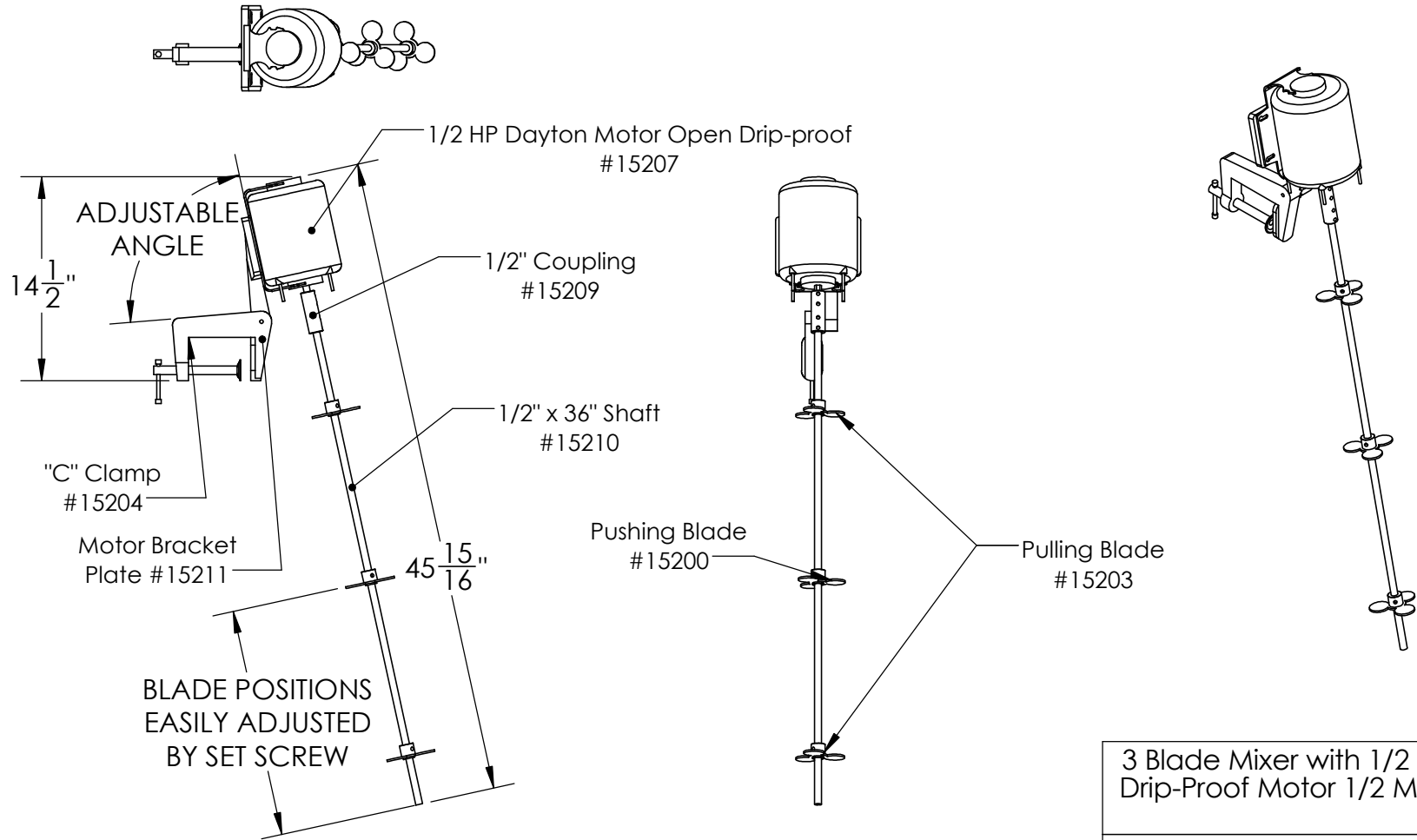

3 Blade Mixer with 1/2 HP, Open Drip-Proof Motor 1/2 Motor Shaft



DIMENSIONS ARE IN INCHES TOLERANCE: ± 1/4"		NAME	DATE
MATERIAL	XXXX	DRAWN	NJV 7/26/23
CAPACITY	XX US gal.	APPROVED	
GRADUATIONS	XX gal.	COMMENTS:	
NOMINAL WALL THICKNESS	XX"	XXXX	XXXX

PROPRIETARY AND CONFIDENTIAL
THE INFORMATION CONTAINED IN THIS DRAWING IS THE SOLE PROPERTY OF TAMCO. ANY REPRODUCTION IN PART OR AS A WHOLE WITHOUT THE WRITTEN PERMISSION OF TAMCO IS PROHIBITED.

XXXX
XXXX

STOCK NO.	REV
15202	A
DO NOT SCALE DRAWING	WEIGHT: 30.4 lbs.