

DETAIL A

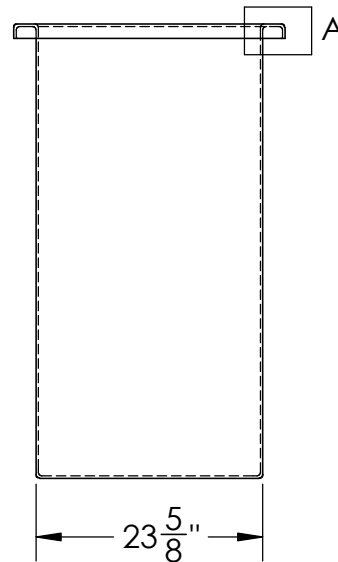

Black Heavy Duty Polyethylene  
Tank w/ External Flange  
#15310

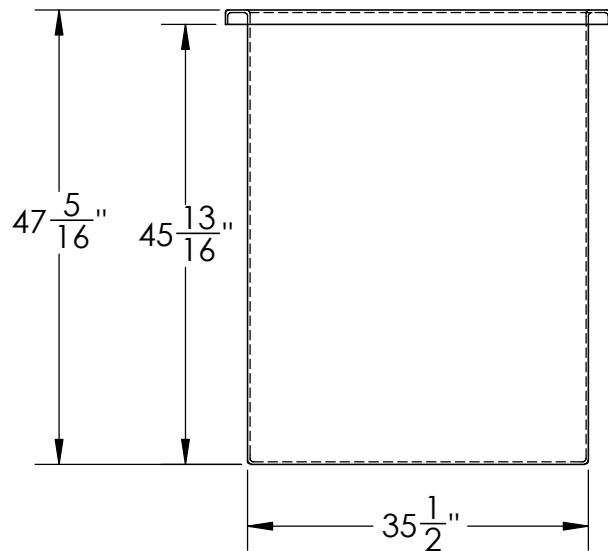
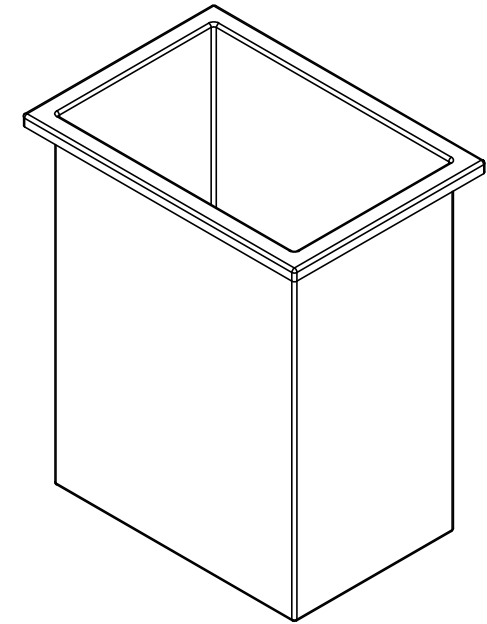

STOCK NO. **15310** REV **A**

DO NOT SCALE DRAWING

WEIGHT: 58 lbs.

DIMENSIONS ARE IN INCHES  
TOLERANCE: ± 1/4"

MATERIAL  
LLDPE - FDA resin

CAPACITY  
180 US gal.

GRADUATIONS  
NO

NOMINAL WALL THICKNESS  
1/4"

	NAME	DATE
DRAWN	JMP	05/29/20
APPROVED		

COMMENTS:

Black  
UV Stabilized

**PROPRIETARY AND CONFIDENTIAL**

THE INFORMATION CONTAINED IN THIS DRAWING IS THE SOLE PROPERTY OF TAMCO. ANY REPRODUCTION IN PART OR AS A WHOLE WITHOUT THE WRITTEN PERMISSION OF TAMCO IS PROHIBITED.

MAX. OPERATING TEMP. 140°F  
INTERMITTENT SERVICE TO 160°F  
SEE CHEMICAL RESISTANCE  
CHART FOR COMPATIBILITY