

3/4" NPT HDPE
Flow Spigot #16482

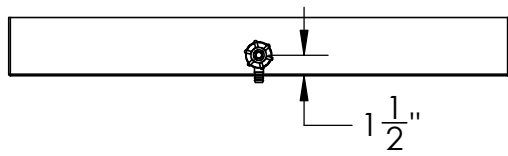

Polyethylene Tray/Tip
Plating Tank #15462

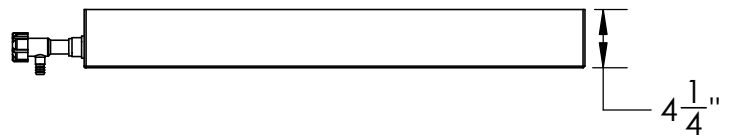
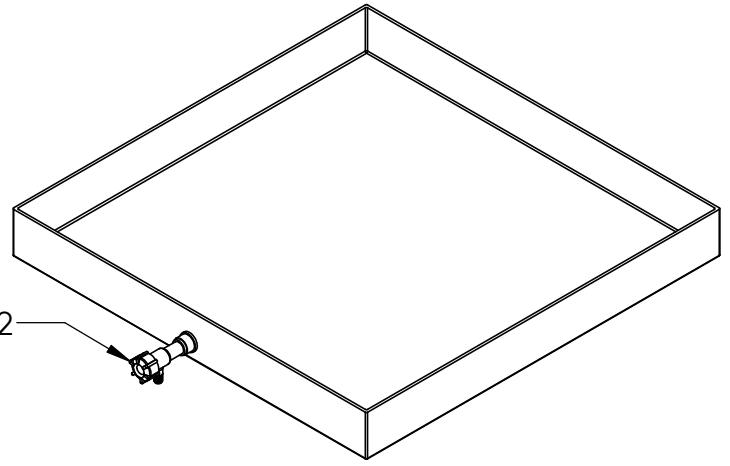

1390 Neubrecht Road
Lima, Ohio 45801

STOCK NO. **15462** REV **A**

DO NOT SCALE DRAWING WEIGHT: 17.5 lbs.

DIMENSIONS ARE IN INCHES TOLERANCE: ± 1/4"		NAME	DATE
MATERIAL	WELDED PE	DRAWN	JMP 6/4/19
CAPACITY	N/A	APPROVED	
GRADUATIONS	N/A	COMMENTS: Other tray sizes, special partitions, flanges, outlets, etc. are available	
NOMINAL WALL THICKNESS	1/4"		

PROPRIETARY AND CONFIDENTIAL
THE INFORMATION CONTAINED IN THIS
DRAWING IS THE SOLE PROPERTY OF
TAMCO. ANY REPRODUCTION IN PART
OR AS A WHOLE WITHOUT THE WRITTEN
PERMISSION OF TAMCO IS PROHIBITED.

MAX. OPERATING TEMP. 140°F
INTERMITTENT SERVICE TO 160°F
SEE CHEMICAL RESISTANCE
CHART FOR COMPATIBILITY