

3/4" NPT PP
Flow Spigot # 16484

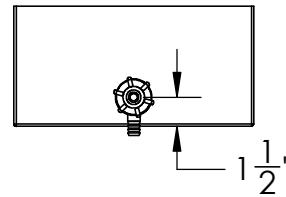

Polypropylene Tray/Tip
Plating Tank #15466

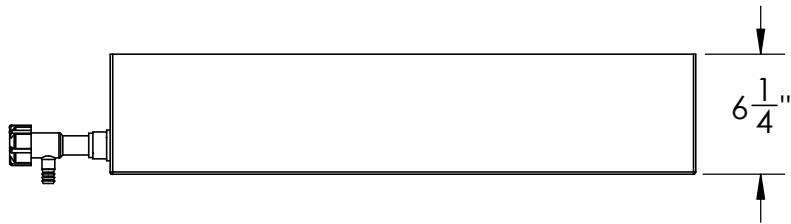
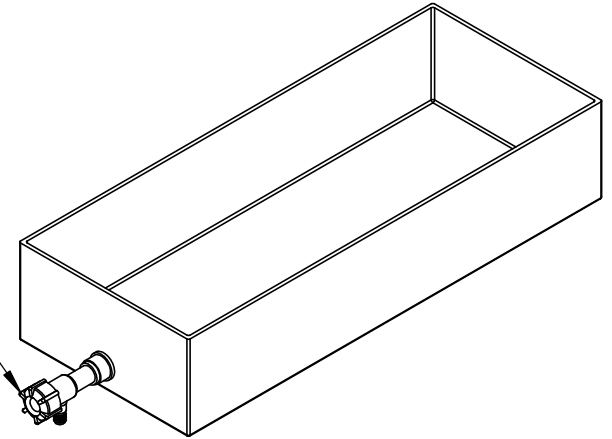

1390 Neubrecht Road
Lima, Ohio 45801

STOCK NO.

15466

REV

A

DO NOT SCALE DRAWING

WEIGHT: 8.5 lbs.

DIMENSIONS ARE IN INCHES
TOLERANCE: $\pm 1/4$ "

MATERIAL
WELDED PP

CAPACITY
N/A

GRADUATIONS
N/A

NOMINAL WALL THICKNESS
1/4"

	NAME	DATE
DRAWN	JMP	6/5/19
APPROVED		

COMMENTS:
Other tray sizes,
special partitions,
flanges, outlets, etc.
are available

PROPRIETARY AND CONFIDENTIAL

THE INFORMATION CONTAINED IN THIS
DRAWING IS THE SOLE PROPERTY OF
TAMCO. ANY REPRODUCTION IN PART
OR AS A WHOLE WITHOUT THE WRITTEN
PERMISSION OF TAMCO IS PROHIBITED.

MAX. OPERATING TEMP. 140°F
INTERMITTENT SERVICE TO 160°F
SEE CHEMICAL RESISTANCE
CHART FOR COMPATIBILITY