

A B C D 4 3 2 1

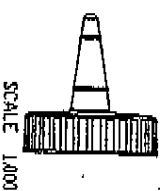
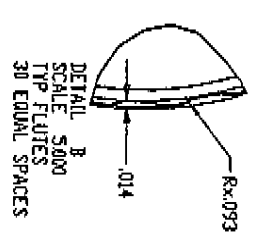
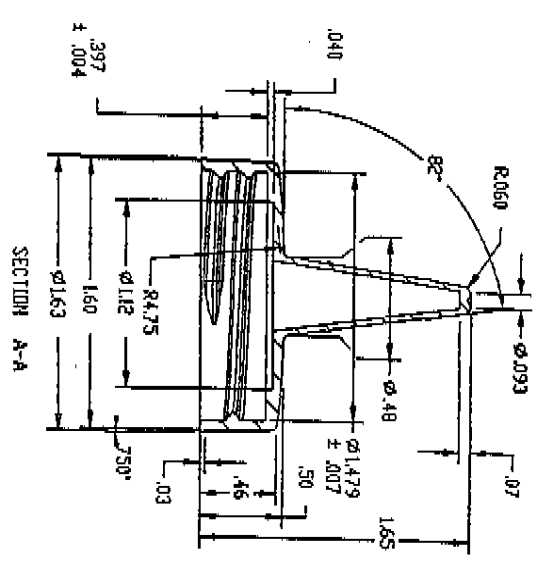
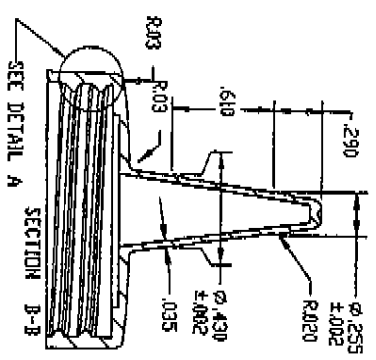
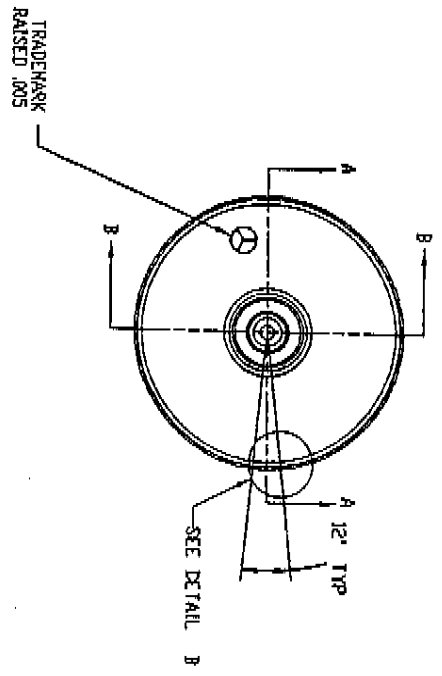
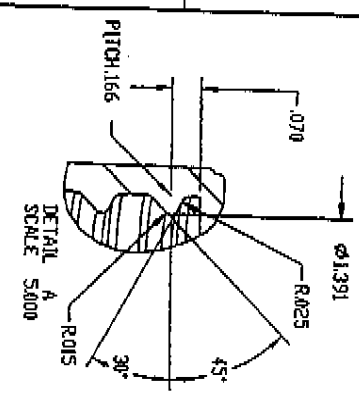

- Notes:
1. Material - Medium Density Polyethylene
 2. Color - As Ordered
 3. Hole Size Available - .020, .030, .055, .090 or no hole as shown.
 4. Thread Spec: Yorker Butress Form (1 1/2 Turns of Full Thread)
 5. Torque Spec. - Tightening Force 17 - 26 in-Lbs
 6. Surface Finish Sp2 - SPI #3

FOR APPROVAL BY CUSTOMER, THIS DRAWING IS SUBJECT TO THE FOLLOWING CONDITIONS: 1. THIS DRAWING IS THE PROPERTY OF YORKER PACKAGING. 2. IT IS TO BE USED ONLY FOR THE PART AND QUANTITY SPECIFIED. 3. IT IS NOT TO BE REPRODUCED OR TRANSMITTED IN ANY FORM OR BY ANY MEANS, ELECTRONIC OR MECHANICAL, INCLUDING PHOTOCOPYING, RECORDING, OR BY ANY INFORMATION STORAGE AND RETRIEVAL SYSTEM. 4. IT IS NOT TO BE USED FOR ANY OTHER PART OR FOR ANY OTHER QUANTITY WITHOUT THE WRITTEN PERMISSION OF YORKER PACKAGING. 5. IT IS NOT TO BE USED FOR ANY OTHER PART OR FOR ANY OTHER QUANTITY WITHOUT THE WRITTEN PERMISSION OF YORKER PACKAGING. 6. IT IS NOT TO BE USED FOR ANY OTHER PART OR FOR ANY OTHER QUANTITY WITHOUT THE WRITTEN PERMISSION OF YORKER PACKAGING.

NO.	DATE	BY	CHKD.	APPROVED
	02/20/04	JMN		
DESIGNER: JMN				
CHECKED: DATE:				
APPROVED:				
CUSTOMER: YORKER				
CUSTOMER PART NO. VARIOUS				
YORKER PART NO. VARIOUS				
VENDOR PART NO. VARIOUS				
VENDOR HOLD NO.				
SCALE AS NOTED				
SHEET 1 OF 1				



YORKER PACKAGING
 ENGRAVING TITLES
 SPLIT CAP 38 MM 400 FINISH
 ANTIKOR ENGRAVING NO.
 SIZE C

REVISION	DATE	BY	CHKD.	APPROVED
C	2/20/04	JMN		
CORRECTED MATERIAL REQUIRED IN 3D				
DESCRIPTION				
DRAWN				
CHECKED				
APPROVED				