

71 oz Grip

Part Number: 2050

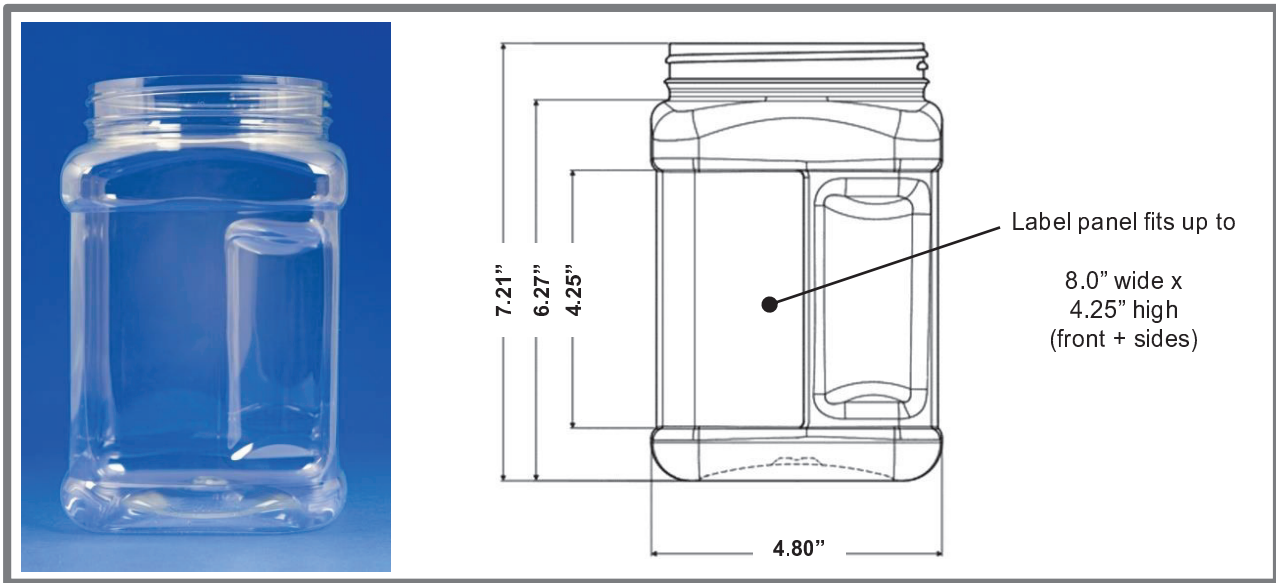

High clarity PET containers



Perfect for cold-filled products: nuts, salsa, candy, pet treats, grated cheese. Ideal when you want to emphasize the premium quality appearance of your product.

Brim Capacity	64 fl oz (2100 ml)
Neck Diameter / Finish	110 mm / 400
Nominal dimensions	4.6 x 4.75 x 7.2" high
Grip length	3.50"
Approx. Weight	100 g

The optimal packaging for virtually anything that would benefit from a high clarity, lightweight, almost unbreakable jar. Completely BPA-free. Recyclable.

For more information, samples and assistance, please contact us at:

Zenith Global, LLC
 1100 Sutton St
 Howell, MI 48843
 Phone: (517) 546-7402
 Fax: (517) 546-1021

Zenith Global is certified by NSF International for the production of food contact packaging.



The statements, technical information and recommendations contained herein are believed to be accurate as of the date hereof. The information provided herein relates only to the specific product designated and may not be applicable when such product is used in combination with other materials or in any process. Since the conditions and methods of use of the product and of the information referred to herein are beyond our control, Seller expressly disclaims any and all liability as to any results obtained or arising from any use of the product or reliance on such information; NO WARRANTY OF FITNESS FOR ANY PARTICULAR PURPOSE, WARRANTY OF MERCHANTABILITY OR ANY OTHER WARRANTY, EXPRESSED OR IMPLIED, IS MADE CONCERNING THE GOODS DESCRIBED OR THE INFORMATION PROVIDED HEREIN.