

83B Cap

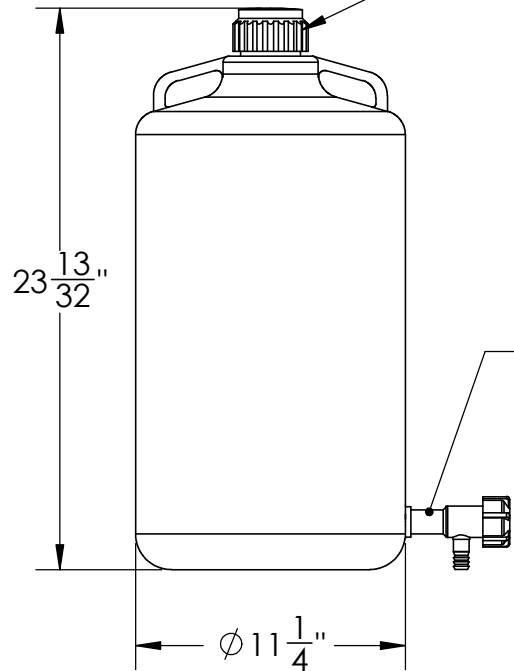

Spigot #16482

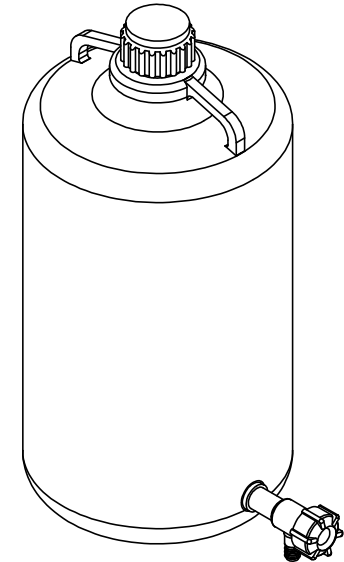
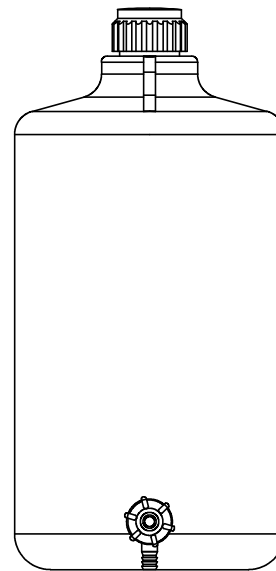

Nalgene LDPE Bottle  
Modified by Tamco with a  
Flow Spigot #67009



1390 Neubrecht Road  
Lima, Ohio 45801

STOCK NO.

67009

REV

A

DO NOT SCALE DRAWING

WEIGHT: 4.6 lbs.

DIMENSIONS ARE IN INCHES TOLERANCE: ± 1/4"		NAME	DATE
MATERIAL	LDPE	DRAWN	CDH 07/08/16
CAPACITY	6-1/2 US gal.	APPROVED	BAT 07/13/16
GRADUATIONS	NO	COMMENTS: Polypropylene Cap	
NOMINAL WALL THICKNESS	0.15"		

**PROPRIETARY AND CONFIDENTIAL**

THE INFORMATION CONTAINED IN THIS DRAWING IS THE SOLE PROPERTY OF TAMCO. ANY REPRODUCTION IN PART OR AS A WHOLE WITHOUT THE WRITTEN PERMISSION OF TAMCO IS PROHIBITED.

MAX. OPERATING TEMP. 140°F  
INTERMITTENT SERVICE TO 160°F  
SEE CHEMICAL RESISTANCE  
CHART FOR COMPATIBILITY