

83B Cap

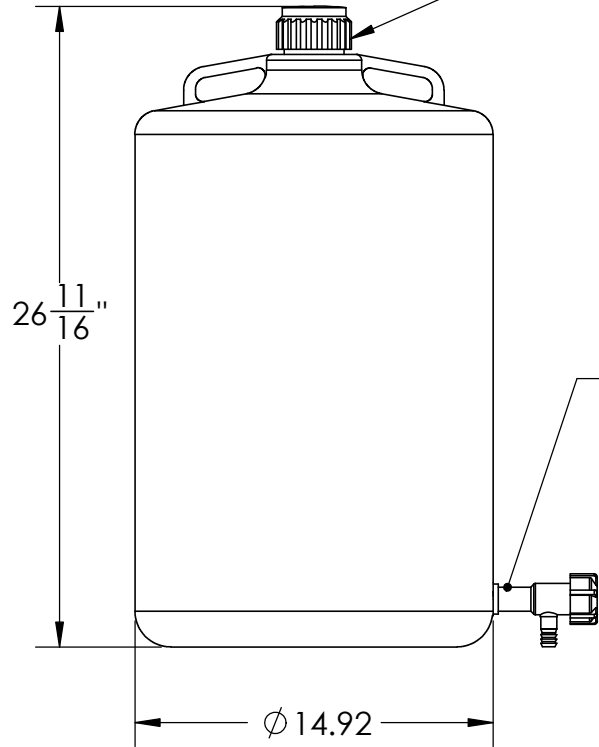

Spigot # 16482

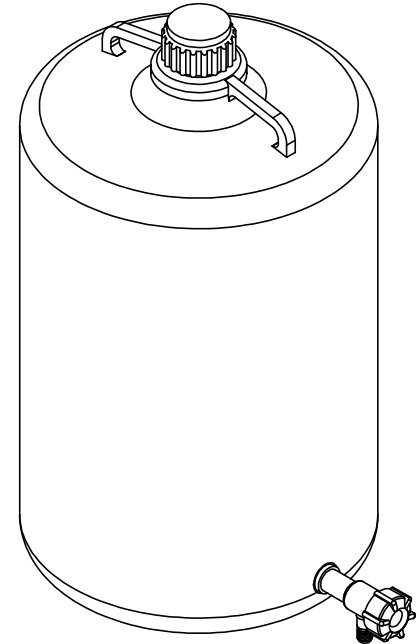

Nalgene LDPE Bottle
Modified by Tamco with a
Flow Spigot #67010



1390 Neubrecht Road
Lima, Ohio 45801

STOCK NO.	67010	REV	A
DO NOT SCALE DRAWING		WEIGHT: 11.4 lbs.	

DIMENSIONS ARE IN INCHES TOLERANCE: ± 1/4"		NAME	DATE
MATERIAL	LDPE	DRAWN	CDH 07/08/16
CAPACITY	13 US gal.	APPROVED	BAT 07/13/16
GRADUATIONS	NO	COMMENTS: Polypropylene Cap	
NOMINAL WALL THICKNESS	0.18"		

PROPRIETARY AND CONFIDENTIAL
THE INFORMATION CONTAINED IN THIS DRAWING IS THE SOLE PROPERTY OF TAMCO. ANY REPRODUCTION IN PART OR AS A WHOLE WITHOUT THE WRITTEN PERMISSION OF TAMCO IS PROHIBITED.

MAX. OPERATING TEMP. 140°F
INTERMITTENT SERVICE TO 160°F
SEE CHEMICAL RESISTANCE
CHART FOR COMPATIBILITY