

83B Cap

20  $\frac{13}{16}$ "

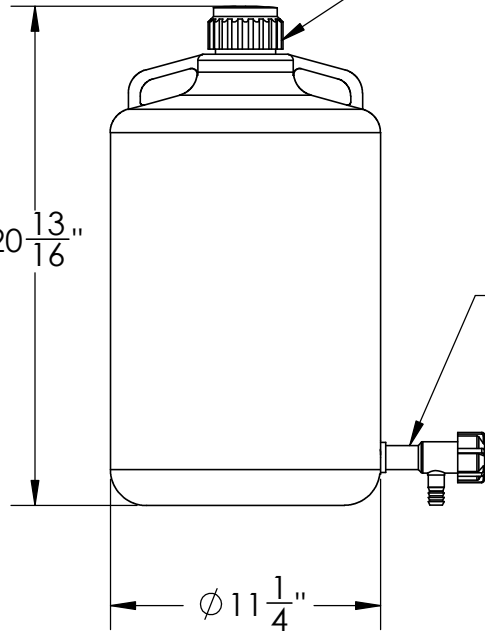

Spigot #16482

$\phi 11 \frac{1}{4}$ "

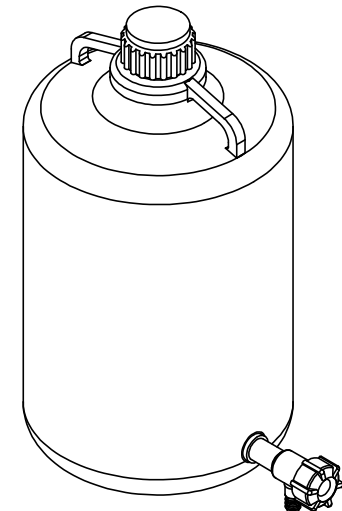
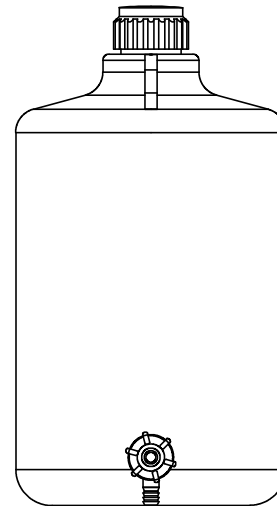

Nalgene LDPE Bottle  
Modified by Tamco with a  
Flow Spigot #67011



1390 Neubrecht Road  
Lima, Ohio 45801

STOCK NO.

67011

REV

A

DO NOT SCALE DRAWING

WEIGHT: 5 lbs.

DIMENSIONS ARE IN INCHES  
TOLERANCE:  $\pm 1/4$ "

MATERIAL  
LDPE

CAPACITY  
5 US gal.

GRADUATIONS  
NO

NOMINAL WALL THICKNESS  
0.16"

	NAME	DATE
DRAWN	CDH	07/08/16
APPROVED	BAT	07/13/16

COMMENTS:

Polypropylene Cap

**PROPRIETARY AND CONFIDENTIAL**

THE INFORMATION CONTAINED IN THIS DRAWING IS THE SOLE PROPERTY OF TAMCO. ANY REPRODUCTION IN PART OR AS A WHOLE WITHOUT THE WRITTEN PERMISSION OF TAMCO IS PROHIBITED.

MAX. OPERATING TEMP. 140°F  
INTERMITTENT SERVICE TO 160°F  
SEE CHEMICAL RESISTANCE  
CHART FOR COMPATIBILITY