

| ACCESSORIES |      |             |               |
|-------------|------|-------------|---------------|
| MK          | SIZE | DESCRIPTION | DEG ELEV DOME |
|             |      |             |               |
|             |      |             |               |
|             |      |             |               |
|             |      |             |               |
|             |      |             |               |
|             |      |             |               |
|             |      |             |               |
|             |      |             |               |
|             |      |             |               |
|             |      |             |               |
|             |      |             |               |
|             |      |             |               |

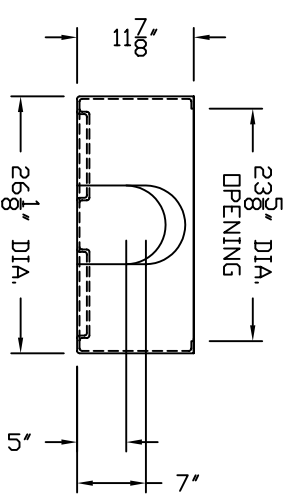
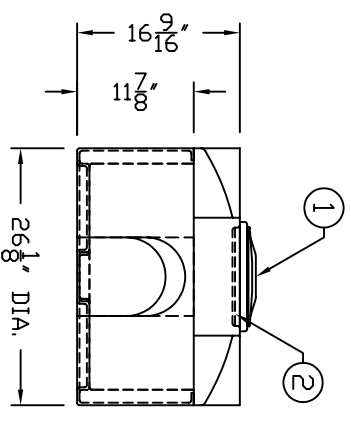
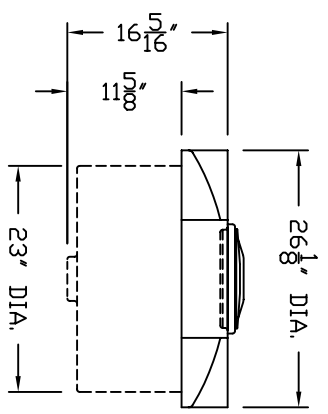
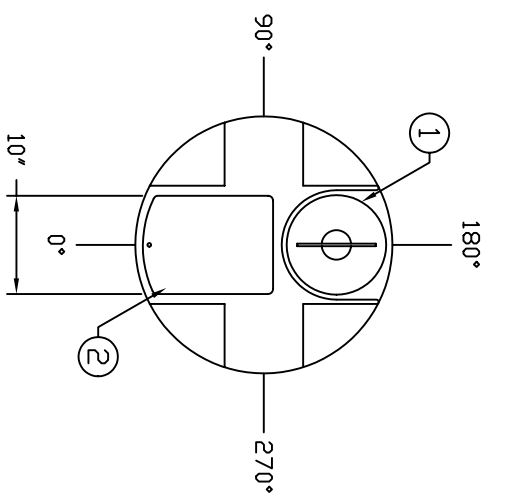

- NOTES:
- 1 7" ACCESS W/ THREADED LID AND RIM
  - 2 MOLDED IN PUMP SHELF
  - 3 PRIMARY CALCULATED GALLONS PER INCH: 1,721 GPI
  - 4 CALCULATED STRAIGHT SIDE CAPACITY: 20,009 GAL.
  - 5 SECONDARY CALCULATED GALLONS PER INCH: 2,233 GPI
  - 6 CALCULATED STRAIGHT SIDE CAPACITY: 25,954 GAL.

|  |  |   |
|--|--|---|
| REV  | REVISION DESCRIPTION   | REV DATE  |
|  | N/A  |   |
|  |  |   |
| 300 N TAYLOR ROAD<br>GARRETT, IN 46738<br>PHONE: (860) 357-3181<br>FAX: (860) 357-3738   |  | CUSTOMER APPROVAL<br>D. MYERS<br>10/22/03   |
| PRIMARY VESSEL<br>SPECIFIC GRAVITY<br>TANK WEIGHT<br>TANK COLOR<br>POLYETHYLENE<br>TITLE<br>DOUBLE WALL STORAGE TANK<br>ASSMANN CORPORATION OF AMERICA<br>ALL DIMENSIONS ARE IN INCHES AND ARE ±3% | CORPORATION OF AMERICA<br>SPECIFIC GRAVITY<br>TANK WEIGHT<br>TANK COLOR<br>POLYETHYLENE<br>IMT 20 GAL. | TANK WEIGHT<br>TANK COLOR<br>SPECIFIC GRAVITY<br>TANK WEIGHT<br>TANK COLOR<br>SP.G. MAX<br>- LBS.<br>- LBS.<br>- LBS.<br>- LBS.<br>- LBS. |
| DWG NUMBER: IMT 20   | REV: -   |   |