

PROPRIETARY DATA

PROPERTY OF DEN HARTOG INDUSTRIES, INC. INFORMATION FURNISHED HEREIN IS THE PROPERTY OF DEN HARTOG INDUSTRIES, INC. AND SHALL NOT BE USED, DISCLOSED TO OTHERS, OR COPIED WITHOUT THE EXPRESSED WRITTEN CONSENT OF DEN HARTOG INDUSTRIES, INC. ALL RIGHTS RESERVED.

MATERIAL/PART SCHEDULE

FS0535-SBPJS

C

PART#	DESCRIPTION	QTY.
S-14GA	14GA STEEL SHEET	360 SI
SJ10937	3/8" FLAT WASHER	4

FS0535-SBPJ | 2 PER SET

©

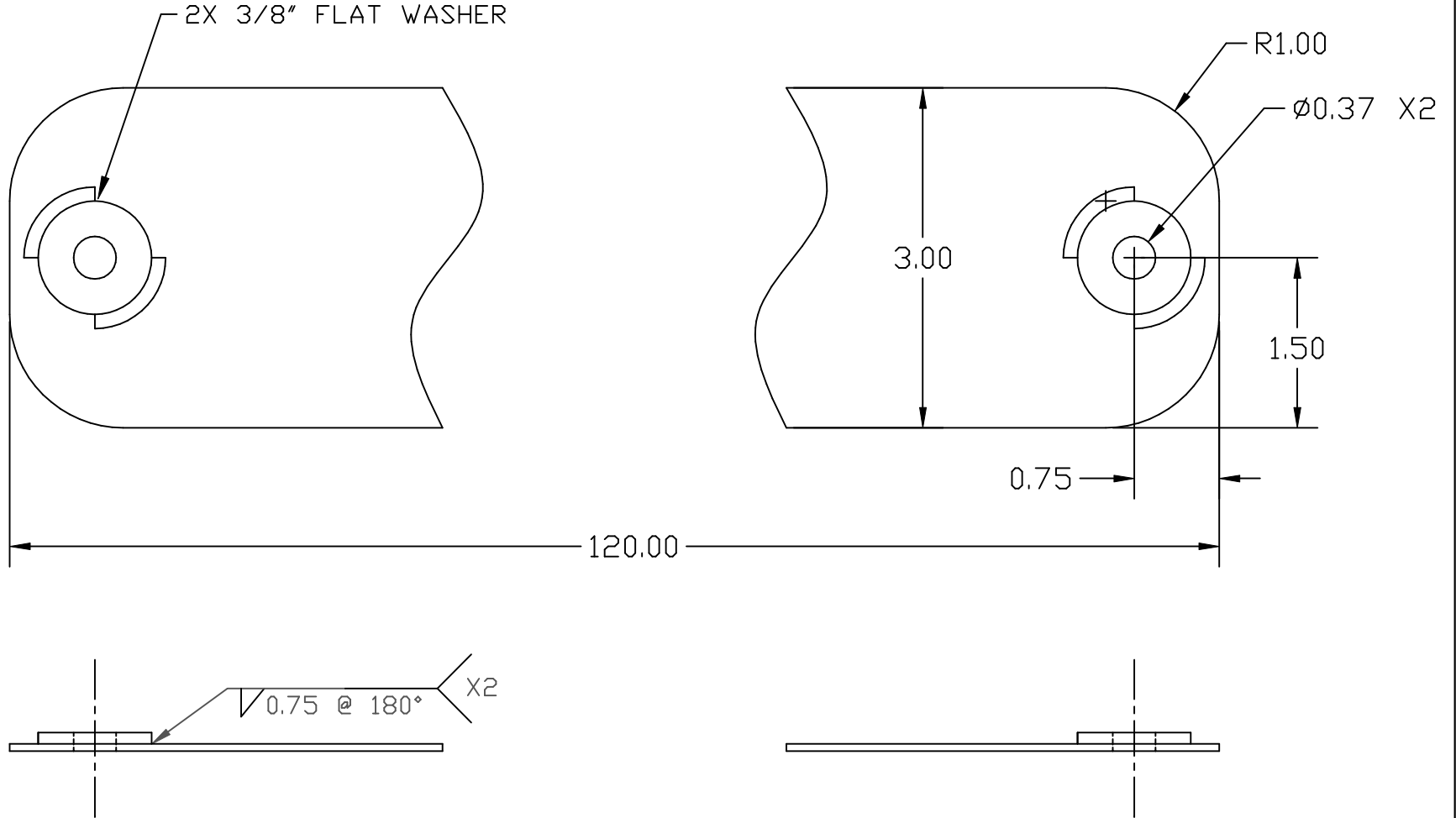

REV	DESCRIPTION	DATE	APPRD	DRAWN / DATE	MATERIAL
C	ADD TEXT BOX	4/2/07	GWC	NVE 12/7/05	14GA (.0747) MILD STEEL
B	TOLERANCE WAS 1% @ 68° F	3/16/07	GWC		
A	UPDATED PRINT, ADDED WELD DESC.	6/22/06	NVE	REH/1/13/06	

ACE ROTO-MOLD
 A DIVISION OF DEN HARTOG INDUSTRIES, INC.
 4018 HWY. 60 BLVD., BOX 421, HOSPERS, IOWA 51238

CLIENT / DESCRIPTION
 STEEL BAND (FOR J-BOLT) FOR 535 GALLON LEG TANK

ALL DIMENSIONS ARE IN DECIMAL INCHES
 TOLERANCES UNLESS OTHERWISE SPECIFIED
 DECIMAL +/- .125"
 FRACTION +/- 1/4"
 ANGLE +/- 2°

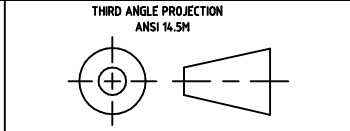

NOTES:
 1. POWDER COATED
 2. WEIGHT 7.6 LBS.

SCALE	N.S.	PART NO.	FS0535-SBPJS
-------	------	----------	--------------