

# PROPRIETARY DATA

PROPERTY OF ACE ROTO-MOLD MFG., INC. INFORMATION FURNISHED HEREIN IS THE PROPERTY OF ACE ROTO-MOLD MFG., INC. AND SHALL NOT BE USED, DISCLOSED TO OTHERS, OR COPIED WITHOUT THE EXPRESSED WRITTEN CONSENT OF ACE ROTO-MOLD MFG., INC. ALL RIGHTS RESERVED.

HE0500-57

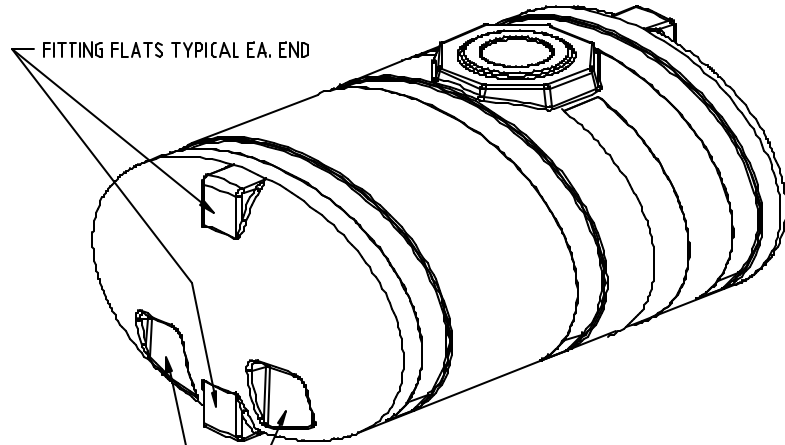

FITTING FLATS TYPICAL EA. END

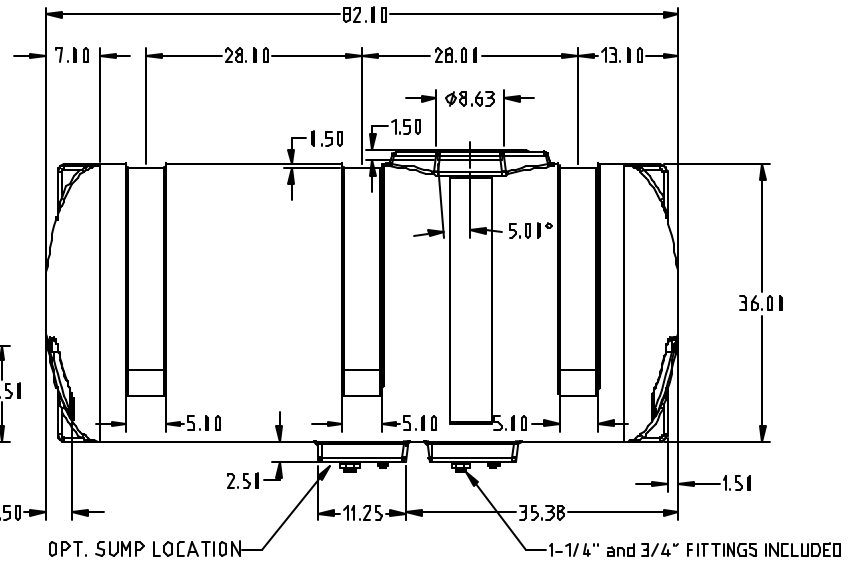
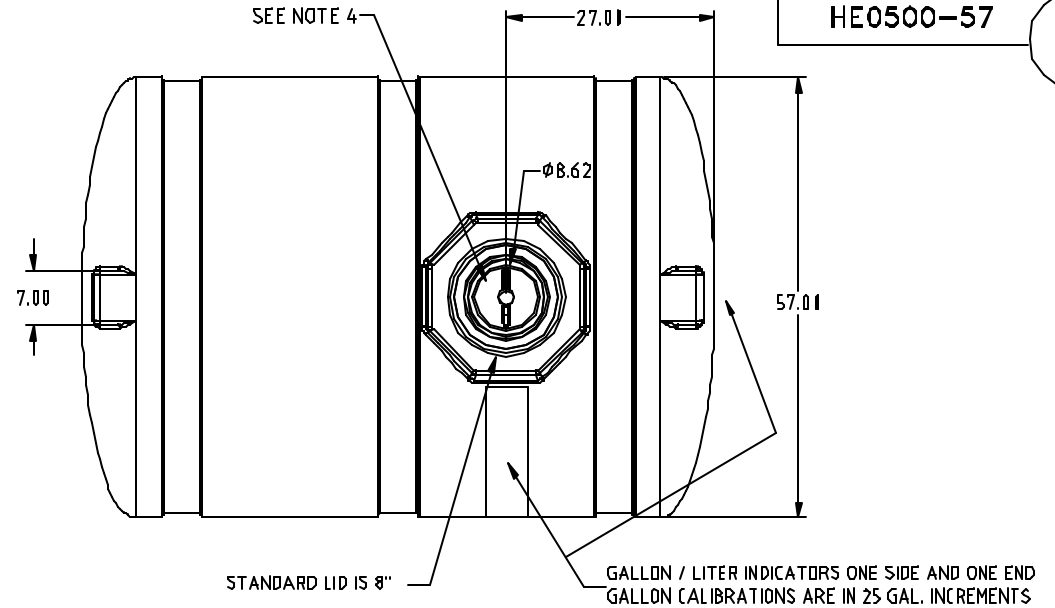
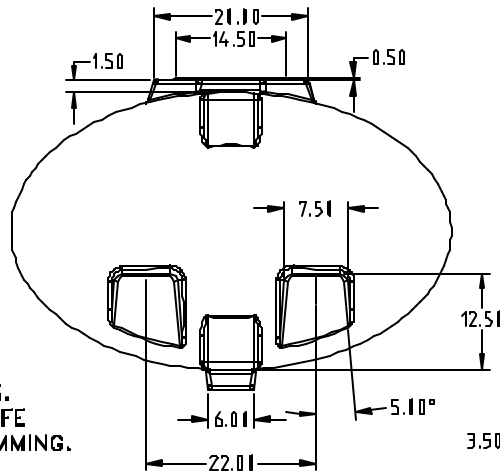

### GENERAL NOTES:

1. USE .027 IN./IN. SHRINK ALLOWANCE
2. MOLD TO BE FULLY WELDED INSIDE AND STITCH WELDED OUTSIDE
3. CLAMPING TO BE WITH 1/2" X 1-1/2" GRADE 8 BOLTS, GRADE 5 NUTS AND NUT HOLDERS.
4. LID RING RECESS TO HAVE KNIFE EDGE ON INSERT TO MINIMIZE TRIMMING.

				DRAWN / DATE REH/4/16/01	MATERIAL / SHOT WEIGHT			
				APPRD. / DATE REH/4/16/01	M111	M134	U625	P938
REV	DESCRIPTION	DATE	APPRD	REH/4/16/01		165		
ALL DIMENSIONS ARE IN DECIMAL INCHES TOLERANCES UNLESS OTHERWISE SPECIFIED ± .5% @ 68° F				THIRD ANGLE PROJECTION ANSI 14.3M	NOTES: 1. .310 NOMINAL WALL			



CLIENT / DESCRIPTION ACE 500 GALLON ELLIPTICAL TANK	
SCALE N.S.	PART NO. HE0500-57