

UNCONTROLLED IF PRINTED; CONTROLLED DOCUMENT LOCATED IN IQMS DOCUMENT CONTROL

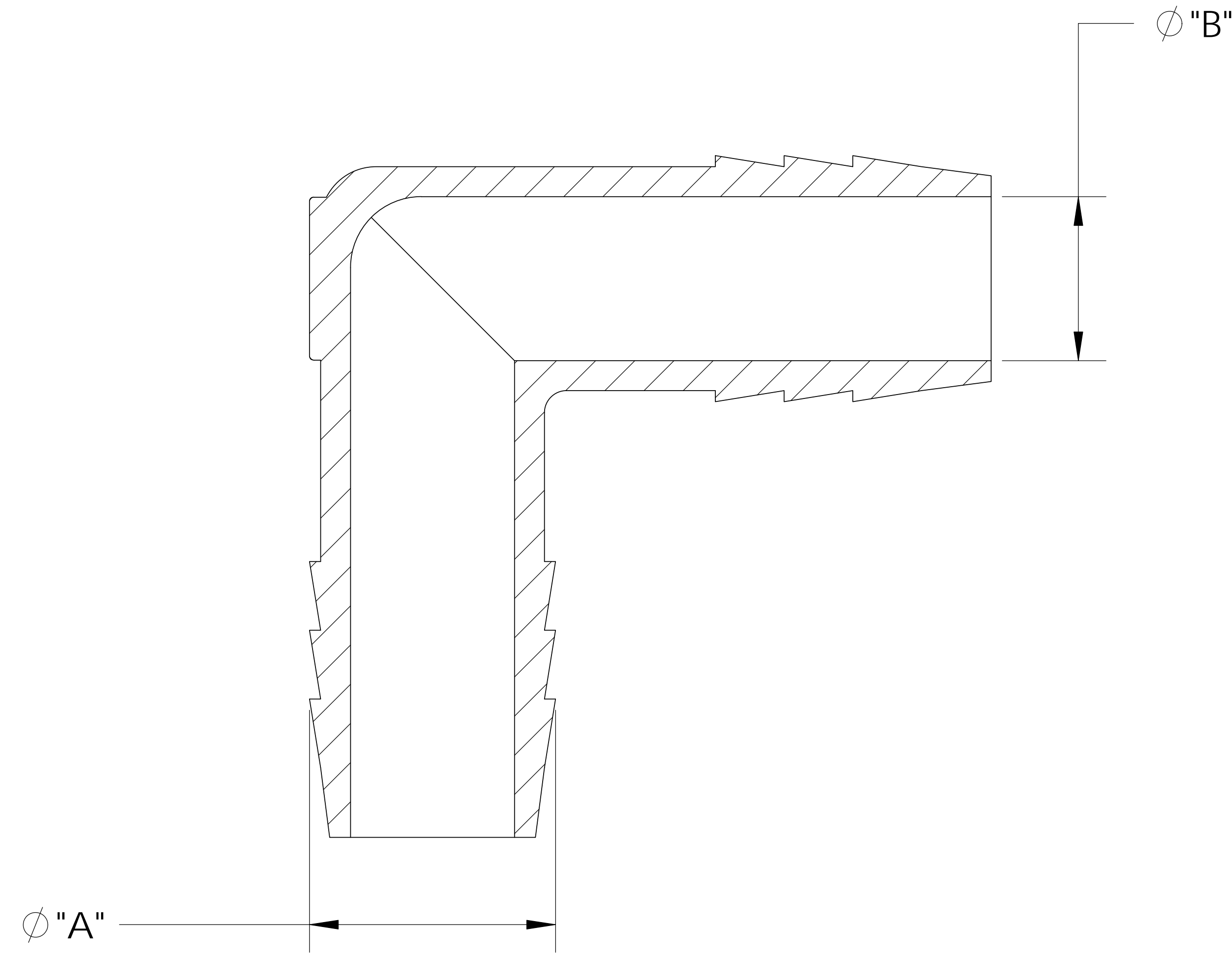

SECTION A-A

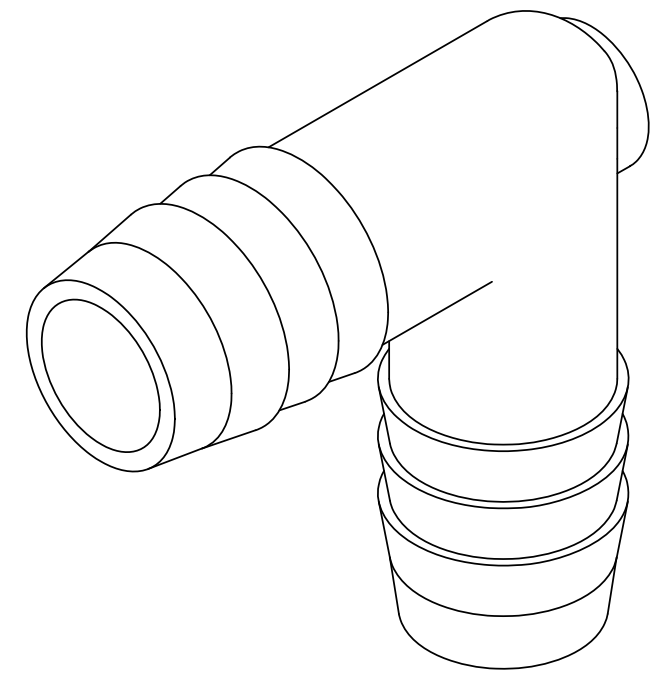
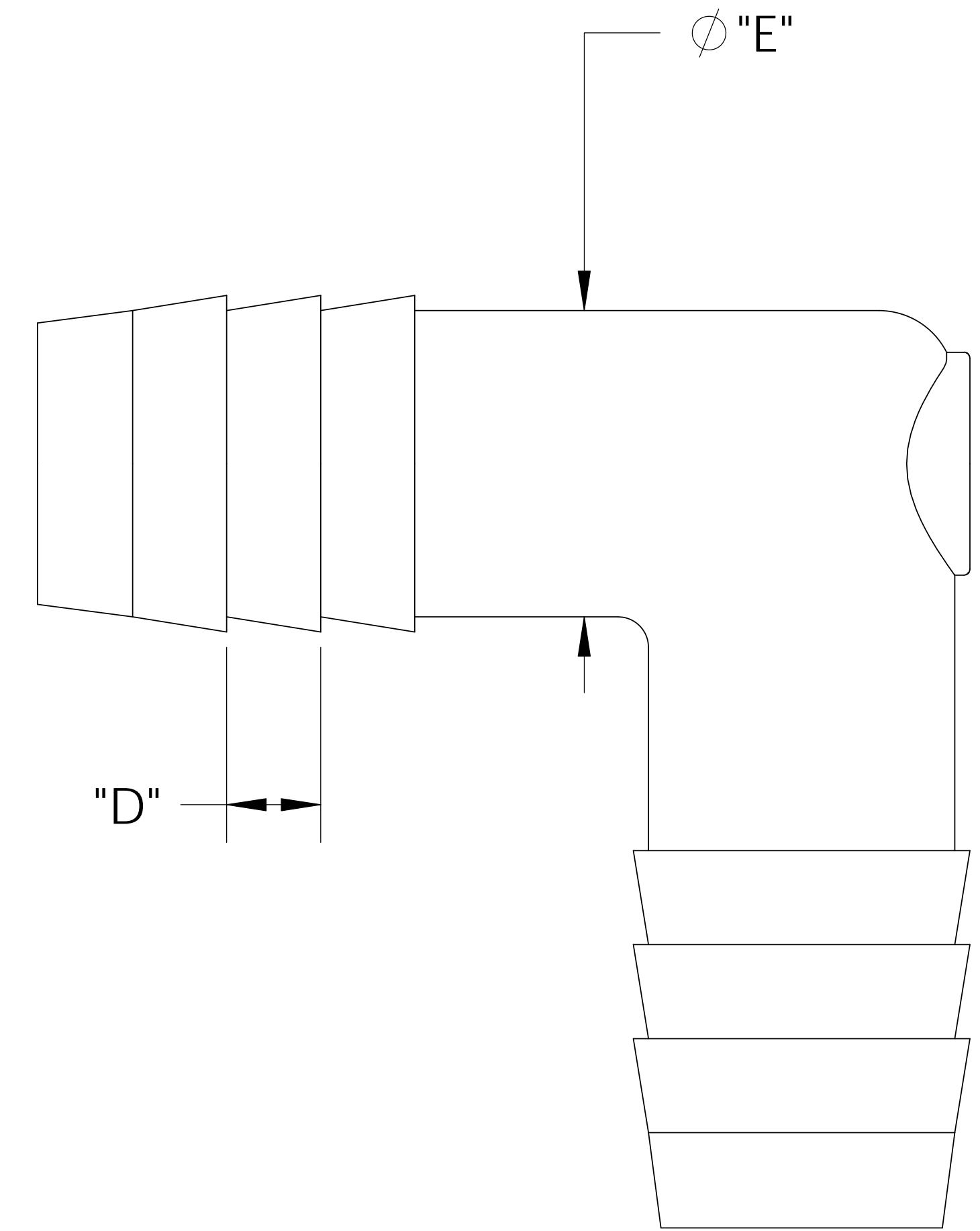
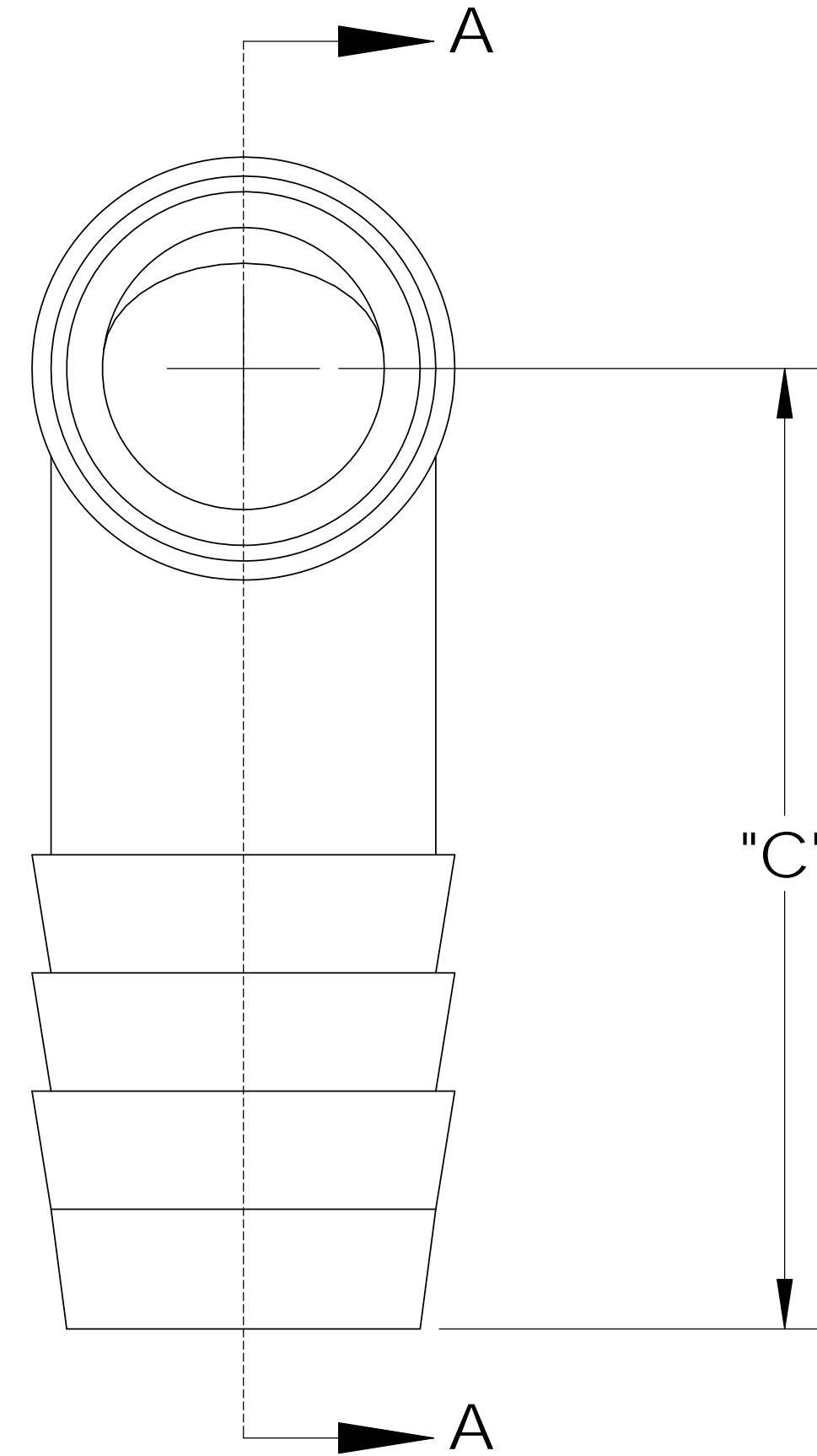

CATALOG NO.	DESCRIPTION	MATERIAL	DIM "A"	DIM "B"	DIM "C"	DIM "D"	DIM "E"
TE2088-T/PP	1/2 X 1/2 PP	POLYPROPYLENE	.550	.370	1.26	.155	.495
TE2088-T/P	1/2 X 1/2 P	POLYETHYLENE	.550	.365	1.23	.140	.500
TE2088-T/N	1/2 X 1/2 N	NYLON	.555	.370	1.26	.155	.505
TE2088-T/K	1/2 X 1/2 K	KYNAR	.555	.370	1.26	.155	.505

SHOWN

NOTES:

- 1) POLYPROPYLENE HAS COLOR OPTIONS:
BLACK = TE2088-T/PPB
NATURAL = TE2088-T/PPN

PROPRIETARY AND CONFIDENTIAL
THE INFORMATION CONTAINED IN THIS DRAWING IS THE SOLE PROPERTY OF THOGUS PRODUCTS COMPANY. ANY REPRODUCTION IN PART OR AS A WHOLE WITHOUT THE WRITTEN PERMISSION OF THOGUS PRODUCTS COMPANY IS PROHIBITED.

D	95.00035	CONVERTED TO 3D FORMAT	UNLESS OTHERWISE SPECIFIED: DIMENSIONS ARE IN INCHES TOLERANCES: ANGULAR: ±0.5° XX = ± 0.1 X.XX = ± 0.05 X.XXX = ± 0.015 REMOVE ALL SHARP EDGES AND BURRS BLEND ALL RADII TO 0.01IN INTERPRET GEOMETRIC TOLERANCING PER: ANSI Y 14.5 1994 MATERIAL: PP, P, N, K FINISH: NA THIRD ANGLE PROJECTION: 	NAME	DATE	 33490 PIN OAK, AVON LAKE, OH 44012 TITLE: BARB ELBOW, 1/2" X 1/2"		
				DRAWN	KDJ		10/22/10	
				CHECKED	KDJ		10/22/10	
				ENG APPR.			XX/XX/XX	
				MFG APPR.			XX/XX/XX	
			Q.A.		XX/XX/XX			
			COMMENTS:					
REV	WRO#	DESCRIPTION	DO NOT SCALE DRAWING			SIZE	DWG. NO.	REV
		HISTORY				B	TE2088-T	F
			SCALE: 2:1			MASS:	SHEET 1 OF 1	