

PRODUCT INFORMATION PACKET



Model No: C42D17FK4C

Catalog No: 098004.00

1/3HP.1750RPM.MSS56C.TEFC.90V.CONT.40C.1.0SF.RIGID C.DC NEMA.C42D17FK4C
SCR



Regal and Leeson are trademarks of Regal Beloit Corporation or one of its affiliated companies.

©2018 Regal Beloit Corporation, All Rights Reserved. MC017097E





Nameplate Specifications

Output HP	0.33 Hp	Output KW	0.25 kW
Voltage	90 V	Current	3.5 A
Speed	1750 rpm	Service Factor	1
Efficiency	82 %	Duty	Continuous
Insulation Class	F	Frame	MSS56C
Enclosure	Totally Enclosed Fan Cooled	Overload Protector	No
Ambient Temperature	40 °C	Drive End Bearing Size	6203
Opp Drive End Bearing Size	6203	UL	Recognized
CSA	Y	CE	N

Technical Specifications

Rotation	Reversible	Mounting	Rigid C base
Overall Length	11.31 in	Frame Length	7.00 in
Shaft Diameter	0.625 in	Shaft Extension	2.06 in
Outline Drawing	027620-098004		

This is an uncontrolled document once printed or downloaded and is subject to change without notice. Date Created: 10/15/2018

RBC PROPRIETARY AND CONFIDENTIAL INFORMATION
 This document is the property of REGAL BELOIT CORPORATION ("RBC") including its subsidiaries and divisions and contains proprietary information of RBC. This document is loaned on the express condition that neither it nor the information contained therein shall be disclosed to others without the express written consent of RBC, and that the information shall be used by the recipient only as approved expressly by RBC. This document shall be returned to RBC upon its request. This document may be subject to certain restrictions under U.S. export control laws and regulations.

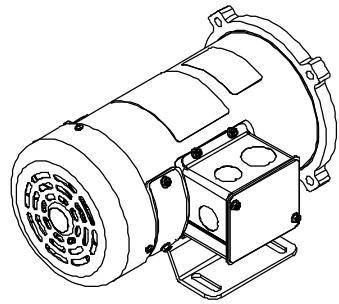
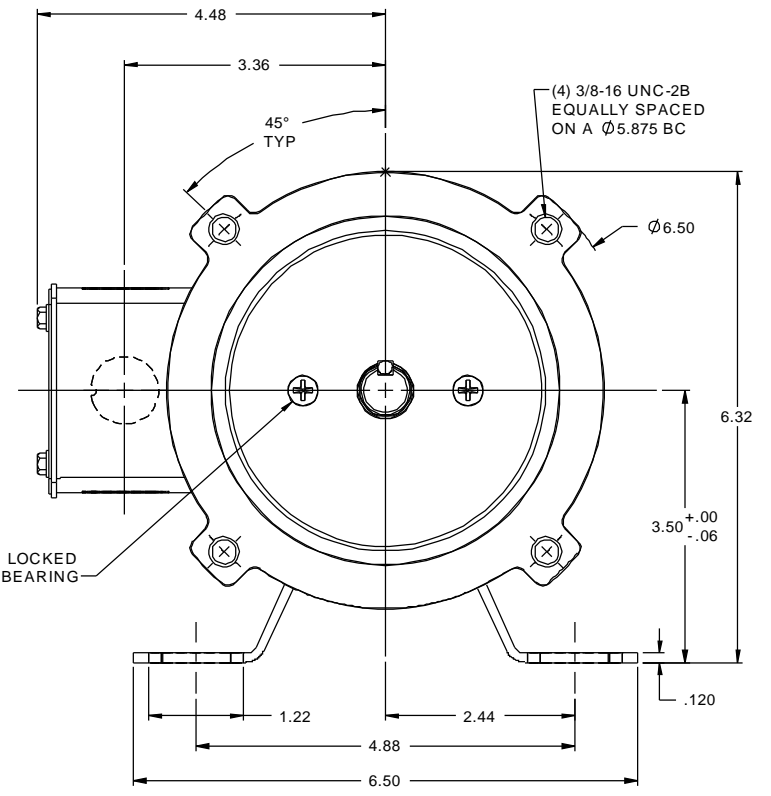
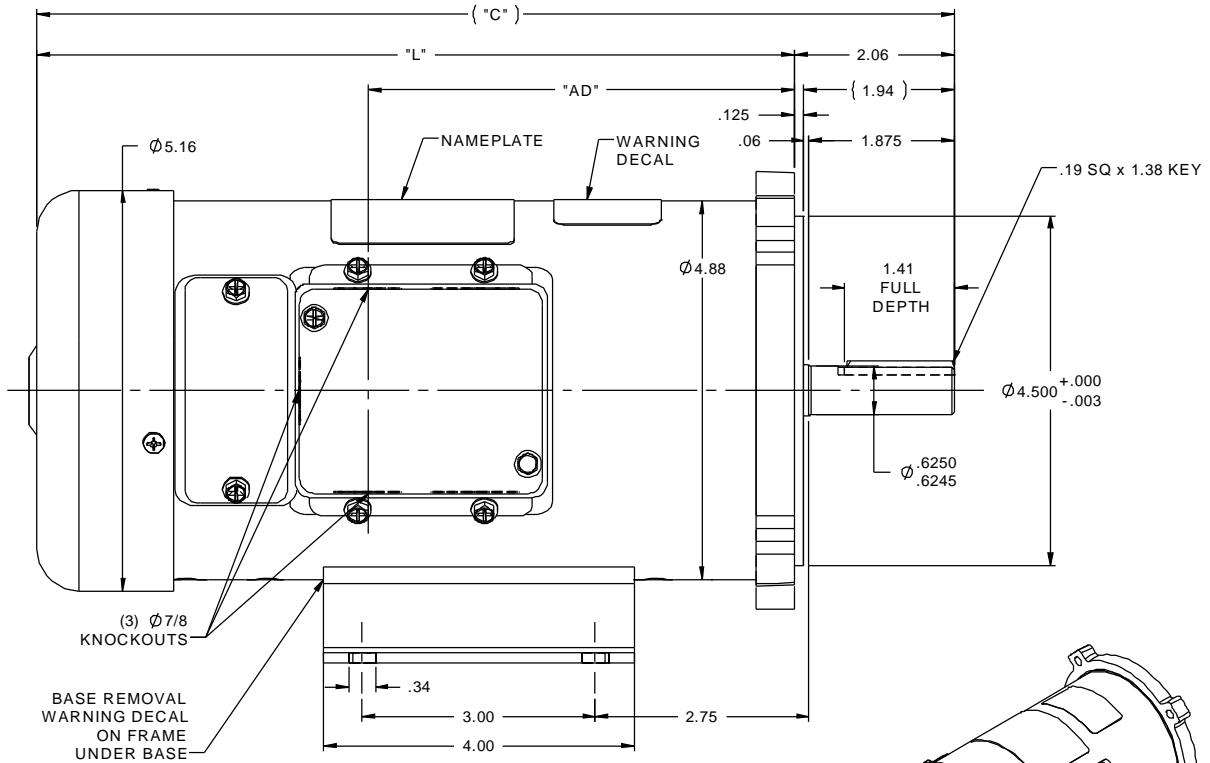

- NOTES:
 1) MAXIMUM FACE RUNOUT .004 T.I.R.
 2) MAXIMUM PILOT ECCENTRICITY .004 T.I.R.
 3) PERMISSIBLE SHAFT RUNOUT .002 T.I.R.
 4) GASKETS THROUGHOUT.

098382.00	10.81	8.75	4.49	48	1/2	1800
098381.00	10.81	8.75	4.49	36	1/2	1800
098069.00	13.81	11.75	7.49	180	3/4	1750
098032.00	13.81	11.75	7.49	90	3/4	1750
098010.00	11.81	9.75	5.49	180	3/4	2500
098009.00	11.81	9.75	5.49	90	3/4	2500
098008.00	11.81	9.75	5.49	180	1/2	1750
098007.00	10.81	8.75	4.49	180	1/2	2500
098006.00	10.81	8.75	4.49	90	1/2	2500
098005.00	11.31	9.25	4.99	180	1/3	1750
098004.00	11.31	9.25	4.99	90	1/3	1750
098003.00	11.31	9.25	4.99	180	1/4	1750
098002.00	10.81	8.75	4.49	90	1/4	1750
098000.00	11.81	9.75	5.49	90	1/2	1750
CATALOG No.	"C"	"L"	"AD"	VOLTS	H.P.	RPM

		TOLERANCES UNLESS SPECIFIED		ELECTRIC MOTORS GEARMOTORS AND DRIVES		DRAWN JRA 5/11/95	
		DEC INCHES		LEESON		CHK	
		X ±.1				APPR	
08 REDRAWN IN SOLIDWORKS, MODIFIED TABLE PER NEW		IPG 9/8/2011		XX ±.03		SCALE 5:8	
STANDARD				XXX ±.005		REF RDOUT42DC8	
07 ADDED FAN GUARD HOLE PLUG, ISAAC 10-4174		IPG 10/11/10		XXXX ±.0005		FMF C42D17FK1	
NO REVISION		BY & DATE		CHK ANG ±1/2°		PAGE OF	
THIRD ANGLE PROJECTION		RFP		FINISH		REV	
		PREV		NETWORK FILE NAME 027620		SIZE B DRAWING NO 027620	
						REV 08	