



Type-57 Butterfly Valve

Specifications

Sizes: Lever: 1-1/2" – 8"
Gear: 1-1/4" – 14"

Models: Wafer Style

Operators: Lever and Gear

Bodies: PVC, PP and PVDF

Discs: PVC, PP, PVDF and CPVC

Seats: EPDM, FKM, and Nitrile

Seals: Same as seating material

Stems: 316 stainless steel, Titanium, Hastelloy C® ‡

**PVC/PP/EPDM Models
NSF-61 Certified**

‡ Trademark of Cabot Corporation

Standard Features (Sizes 1-1/2" – 14")

- Standard model (1-1/2" – 14") has PVC body and PP disc for superior chemical resistance and elevated temperature capabilities
- 316 stainless steel shaft has full engagement over the entire length of the disc and is a non-wetted part
- Only solid and abrasion resistant plastic disc and elastomeric liner are wetted parts
- ISO bolt circle on top flange – No body or stem modifications required for accessories
- Stem retainer – PP retainer to prevent stem removal
- Seat overtightening protection – Molded body stops and seat stress relief area
- Spherical disc design offers increased Cv, ultimate sealing and high cycle life
- 21-position throttle plate for lever handle style

Options

- Pneumatically and electrically actuated with accessories
- Alternate discs:
 - (I): PVC : 1-1/2" – 14"
 - (II) PVDF : 1-1/2" – 14"
 - (III) CPVC : 3", 4", 6" & 8"
- Lug style (stainless steel 304 or 316) for blocking and end-of-line applications
- Stems in titanium or Hastelloy C®
- 2" square nut on stem (1-1/2" - 8" only)
- 2" square nut on gear operator (all sizes)
- Stem extensions (single stem and two-piece stem)
- Locking devices (gear type – standard on lever)
- Chain operators
- Manual limit switch - Asahi P-Series
- Tandem arrangements (Patented by A/A, Inc.)

Parts List (Lever: Sizes 1-1/2" – 8")

PARTS			
NO.	DESCRIPTION	PCS.	MATERIAL
1	Body	1	PVC, PP, PVDF
2	Disc	1	PVC, CPVC, PP, PVDF
3	Seat	1	EPDM, FKM, NBR
6	O-Ring (C)	1	EPDM, FKM, NBR
7	Stem	1	Stainless Steel 316
8	Stem Retainer	1	PP
16	Handle	1	PP
16A	Metal Insert in Handle	1	Stainless Steel 316L
17	Handle Lever	1	PPG
18	Pin	1	PPG
19	Spring	1	Stainless Steel 304
20	Washer (A)	1	Stainless Steel 304
21	Bolt (B)	1	Stainless Steel 304
22	Locking Plate	1	PPG
23	Screw (B)	4	Stainless Steel 304
24	Cap (A)	1	PP
156	Liner Stabilization Ring	2	Stainless Steel (SCS13)
157	Screw (F)	4	Stainless Steel 304



Type-57 – Lever Operated

Butterfly Valves

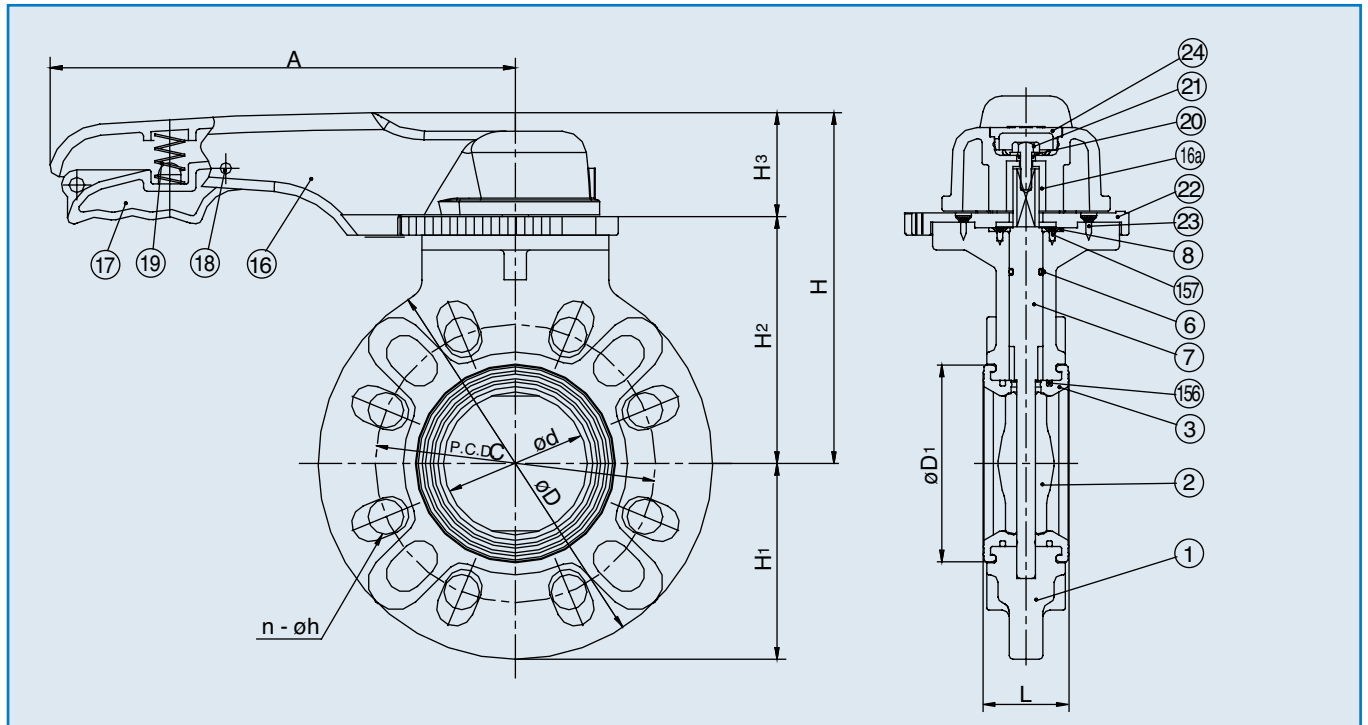

Dimensions (Lever: Sizes 1-1/2" – 8") (in.)

Cv Values

NOMINAL SIZE		ANSI CLASS 150													NOMINAL SIZE		Cv (at various opening degrees)		
INCHES	mm	d	C	n	h	D	D1	L	H	H1	H2	H3	A	INCHES	mm	30°	60°	90°	
1-1/2	40	1.77	3.88	4	0.62	5.91	2.83	1.54	6.14	2.95	3.94	2.20	8.66	1-1/2	40	4	43	71	
2	50	2.20	4.75	4	0.75	6.50	3.23	1.65	6.54	3.25	4.33	2.20	8.66	2	50	7	73	120	
2-1/2	65	2.72	5.50	4	0.75	7.28	3.78	1.81	6.93	3.64	4.72	2.20	8.66	2-1/2	65	15	153	250	
3	80	3.03	6.00	4	0.75	8.31	4.17	1.81	7.52	4.15	5.31	2.20	9.84	3	80	18	183	300	
4	100	4.02	7.50	8	0.75	9.37	5.31	2.20	8.11	4.69	5.91	2.20	9.84	4	100	28	287	470	
5	125	5.08	8.50	8	0.88	10.39	6.69	2.60	9.33	5.20	6.61	2.72	12.60	5	125	49	506	830	
6	150	5.91	9.50	8	0.88	11.22	7.52	2.80	9.92	5.61	7.20	2.72	12.60	6	150	66	671	1100	
8	200	7.68	11.75	8	0.88	13.39	9.53	3.43	11.14	6.69	8.43	2.72	15.75	8	200	150	1525	2500	

Pressure vs. Temperature (psi, water, non-shock)* Wt. (lbs.) / Vacuum Service

BODY		PVC			PP		PVDF			NOMINAL SIZE		PVC			PP			PVDF			NOMINAL SIZE		VACUUM SERVICE (INCHES OF MERCURY)
DISC		PP			PP		PVDF			INCHES	mm	PVC	PP	PVDF	INCHES	mm							
NOMINAL SIZE		30° F	121° F	141° F	- 5° F	141° F	- 5° F	141° F	176° F								211° F						
INCHES	mm	120° F	140° F	175° F	140° F	175° F	140° F	175° F	140° F	175° F	210° F	250° F											
1-1/2	40	150	70	30	150	100	150	100	85	75	1-1/2	40	3	3	3	1-1/2	40	-29.92					
2	50	150	70	30	150	100	150	100	85	75	2	50	4	3	4	2	50	-29.92					
2-1/2	65	150	70	30	150	100	150	100	85	75	2-1/2	65	4	3	4	2-1/2	65	-29.92					
3	80	150	70	30	150	100	150	100	85	75	3	80	5	4	5	3	80	-29.92					
4	100	150	45	30	150	100	150	100	85	75	4	100	6	5	7	4	100	-29.92					
5	125	150	45	30	150	100	150	100	85	75	5	125	11	9	13	5	125	-29.92					
6	150	150	45	30	150	100	150	100	85	75	6	150	13	10	15	6	150	-29.92					
8	200	150	40	20	150	85	150	85	75	60	8	200	21	16	25	8	200	-29.92					

* For lug style data consult factory.

* FKM seat butterfly valves have a lower temperature limit of 23° F

Type-57 – Gear Operated Butterfly Valves

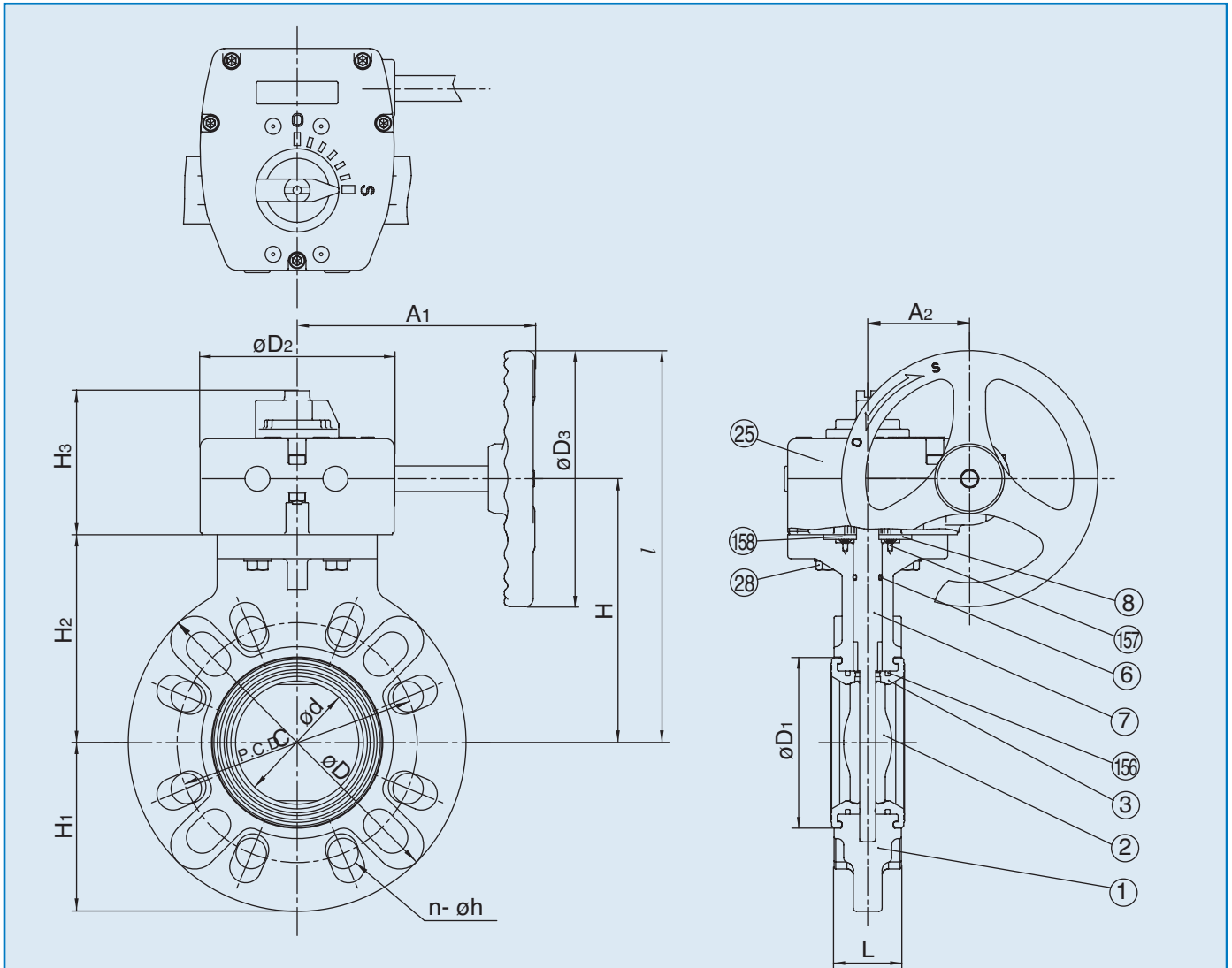

Dimensions (Sizes 1-1/2" – 14") (in.)

NOMINAL SIZE	ANSI CLASS 150					D	D1	D2	D3	L	H	H1	H2	H3	l	A1	A2	Wheel Cycles	Gear Box Model No.
	INCHES	mm	d	C	n														
1-1/2	40	1.77	3.88	4	0.62	5.91	2.83	4.8	6.30	1.54	5.12	2.95	3.74	3.54	8.27	6.57	2.52	9.5	241
2	50	2.20	4.75	4	0.75	6.50	3.23	4.8	6.30	1.65	5.51	3.25	4.13	3.54	8.66	6.57	2.52	9.5	
2-1/2	65	2.72	5.50	4	0.75	7.28	3.78	4.8	6.30	1.81	5.91	3.64	4.53	3.54	9.06	6.57	2.52	9.5	
3	80	3.03	6.00	4	0.75	8.31	4.17	4.8	6.30	1.81	6.50	4.15	5.12	3.54	9.65	6.57	2.52	9.5	
4	100	4.02	7.50	8	0.75	9.37	5.31	4.8	6.30	2.20	7.09	4.69	5.71	3.54	10.24	6.57	2.52	9.5	
5	125	5.08	8.50	8	0.88	10.39	6.69	4.8	6.30	2.60	7.68	5.20	6.30	3.54	10.83	6.57	2.52	9.5	
6	150	5.91	9.50	8	0.88	11.22	7.52	4.8	6.30	2.80	8.27	5.61	6.89	3.54	11.42	6.57	2.52	9.5	
8	200	7.68	11.75	8	0.88	13.39	9.53	4.8	6.30	3.43	9.49	6.69	8.11	3.54	12.64	6.57	2.52	9.5	
10	250	9.84	14.25	12	1.00	16.57	11.89	4.8	6.30	4.33	10.87	8.31	9.49	3.62	14.02	6.57	2.52	9.5	
12	300	11.93	17.00	12	1.00	19.21	14.17	7.4	11.81	5.08	13.39	9.61	11.73	4.25	19.29	10.71	3.90	9.5	243
14	350	13.82	18.75	12	1.12	21.22	15.47	7.4	11.81	5.08	14.45	10.63	12.80	4.25	20.35	10.71	3.90	9.5	

Type-57 – Gear Operated Butterfly Valves

Parts List (Gear: Sizes 1-1/2" – 14")

PARTS			
NO.	DESCRIPTION	PCS.	MATERIAL
1	Body	1	PVC, PP, PVDF
2	Disc	1	PVC, CPVC, PP, PVDF
3	Seat	1	EPDM, FKM, NBR
6	O-Ring (C)	1	EPDM, FKM, NBR
7	Stem	1	Stainless Steel 316
8	Stem Retainer	1	PP
25	Gear Box	1	Plasgear™
28	Bolt (C)	4	Stainless Steel 304
156	Liner Stabilization Ring	2	Stainless Steel (SCS13)
157	Screw (F)	4	Stainless Steel 304
158	Gasket	1	EPDM

Sample Specification

All solid thermoplastic butterfly valves sizes 1-1/2" through 14" shall be of the Type-57 lined body design and bubble-tight seal (meeting or exceeding Class VI as defined by American National Standard Institute) with only the liner and disc as wetted parts. The lever handle (sizes 1-1/2" thru 8") shall have a molded provision for a padlock. Gear operators shall be worm gear design, self-locking Plasgear™. The spherical disc design for higher Cv values shall be of solid, abrasion resistant plastic. Liner shall be molded and formed around the body, functioning as gasket seals with convex ring design on each side of the valve for lower bolt tightening torque and valve body shall have molded body stops and seat relief area to prevent over tightening of mating flanges. Stem shall be of 316 stainless steel, non-wetted, have engagement over the full length of the disc and be locked into valve body by PP stem retainer. Valves shall have a molded ISO bolt pattern on top flange for actuator mount. PVC shall conform to ASTM D1784 Cell Classification 12454A, PP conforming to ASTM D4101 Cell Classification PPO210B67272, and PVDF conforming to ASTM D 3222 Cell Classification Type II. All PVC, PP and PVDF body valves shall be rated to 150psi at 70° F, sizes 1-1/2" through 10" and 100psi for sizes 12" and 14". Butterfly valves shall be wafer style, as manufactured by Asahi/America, Inc.

Troubleshooting

What if fluid still flows when the valve is closed?

1. Make sure lever or gear is in a fully closed position [gear type may require travel stop adjustment].
2. Liner is damaged or worn. Replace liner.
3. Disc is damaged or abraded. Change disc.
4. Foreign material is caught between seat and disc. Remove the substance.
5. Mating flange bolts either overtightened or unevenly tightened. Retighten properly.

What if fluid leaks outside between seat and mating flange?

1. Seat damage. Change seat.
2. Mating flange bolts not tightened with proper torque or unevenly tightened. Retighten to the appropriate torque.

What if valve does not operate smoothly?

1. Foreign material is caught between disc and seat. Remove the material and clean.
2. Lever or gearbox is damaged. Replace.
3. Mating flange bolts overtightened. Retighten.

Caution

- Never remove valve from pipeline under pressure.
- Always wear protective gloves and goggles.

Cv Values

NOMINAL SIZE		30°	60°	90°
INCHES	mm			
8	200	150	1525	2500
10	250	232	2355	3860
12	300	342	3477	5700
14	350	386	3928	6440

Pressure vs. Temperature (psi, water, non-shock)* Wt. (lbs.) / Vacuum Service

BODY		PVC		PP		PVDF				
DISC		PP				PVDF				
NOMINAL SIZE		30° F	121° F	141° F	- 5° F	141° F	- 5° F	141° F	176° F	211° F
INCHES	mm	120° F	140° F	175° F	140° F	175° F	140° F	175° F	210° F	250° F
8	200	150	40	20	150	85	150	85	75	60
10	250	150	40	20	150	85	150	85	75	60
12	300	100	30	15	100	60	100	60	45	30
14	350	100	30	7	100	45	100	45	30	15

NOMINAL SIZE		PVC	PP	PVDF
INCHES	mm			
8	200	24	20	28
10	250	33	27	41
12	300	62	53	76
14	350	67	58	81

NOMINAL SIZE		VACUUM SERVICE (INCHES OF MERCURY)
INCHES	mm	
8	200	-29.92
10	250	-29.92
12	300	-23.62
14	350	-23.62

* For lug style data consult factory.

* FKM seat butterfly valves have a lower temperature limit of 23° F