



PVC & CPVC UTILITY BALL VALVES

UT-2-0306

Economy, Utility and Quality



A high quality, economical quarter-turn shutoff valve designed for irrigation, pool and spa, and general purpose applications. IPS sizes 1/2" - 2" available in PVC White, PVC Gray or CPVC with socket or threaded end connectors. Sizes 3" - 4" available in PVC White with socket or threaded end connectors. 6" size available in PVC White with socket end connectors and high-efficiency lever style handle for easier operation.

PVC White, PVC Gray or CPVC Construction

Excellent companion for PVC systems such as lawn sprinklers, pools, spas, water gardens and other light-duty applications.

One-Piece Sealed Unit

Never requires adjustment.

Teflon® HDPE Ball Seats

Smooth operating Teflon® HDPE floating seat design reduces wear.

EPDM O-ring Seals

High grade, abrasion resistant EPDM elastomer O-rings.

Full Schedule 80 Bore

In full open position, full bore virtually eliminates pressure drop, providing optimum flow.

High Impact Polypropylene Handle

Features double stop engagement.

Safe-T-Shear® Stem

Developed to help prevent line fluids from leaking out in the event of ball valve stem damage. Engineered for high strength, the stem incorporates a special shear point to control accidental breakage. Over torquing breaks occur above the stem O-ring leaving the seal intact until replacement can be made.

150 psi Pressure Rating

Maximum Internal Pressure at 73° F for a variety of applications.

Certified by NSF for Potable Water

All Utility Ball Valves are Certified by NSF International for potable water use.

Sample Engineering Specifications
All thermoplastic ball valves shall be Utility sealed unit type constructed from PVC Type I Cell Classification 12454 or CPVC Type IV Cell Classification 23447. All O-rings shall be EPDM. All valves shall have Safe-T-Shear® stem and double stop Polypropylene handle. All valves shall be listed by NSF for use in potable water service. All valves shall be pressure rated at 150 psi for water at 73° F, as manufactured by Spears® Manufacturing Company.

For additional information, please refer to Spears® THERMOPLASTIC VALVES AND ACCESSORIES PRODUCT GUIDE & ENGINEERING SPECIFICATIONS V-4 and THERMOPLASTIC VALVES & ACCESSORIES Price Schedule V-1.



PROGRESSIVE PRODUCTS FROM SPEARS® INNOVATION & TECHNOLOGY

Visit our web site: www.spearsmfg.com

Teflon® is a registered trademark of Dupont Company.

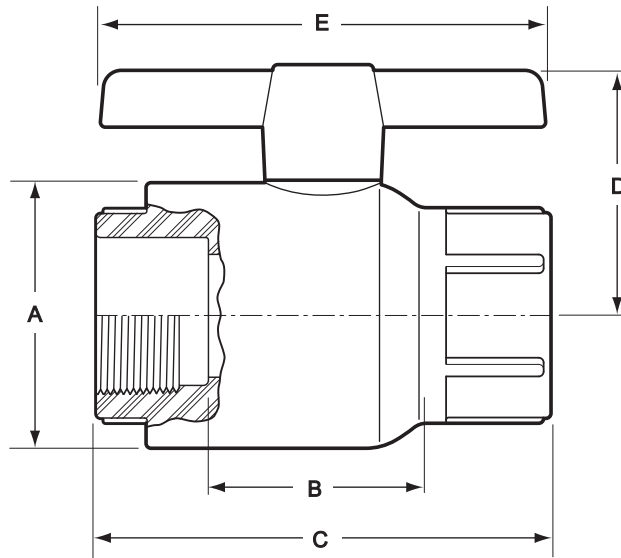

Dimensions, Weights & C_v Values

Nominal Size	Dimension Reference (inches, ± 1/16)					Approx. Wt. (Lbs.)		C _v ² Values
	A	B ¹	C	D	E ³	PVC	CPVC	
1/2	1-7/16	1-1/4	2-11/16	1-11/16	2-3/4	.16	.17	46
3/4	1-25/32	1-7/16	2-31/32	1-29/32	3-7/32	.25	.27	91
1	2-1/32	1-5/8	3-3/8	2-7/16	3-1/2	.34	.36	160
1-1/4	2-9/16	1-31/32	3-7/8	2-13/16	3-3/4	.57	.60	306
1-1/2	2-15/16	2-1/2	4-11/16	2-15/16	4-1/4	.88	.90	429
2	3-9/16	2-27/32	5-5/32	3-13/16	4-31/32	1.34	1.34	755
2-1/2	4-5/16	3-17/32	7-1/32	4-5/32	5-9/16	2.31	N/A	1126
3	5-5/16	4-19/32	8-11/32	5-9/16	7-21/32	4.78	N/A	1660
4	6-11/16	5-21/32	9-11/16	6-6/32	10-27/32	8.00	N/A	3129
6 ³	10-3/16	8-3/32	14-3/16	8-5/32	14-3/32	23.24	N/A	7942

1: Valve Lay Length

2: Gallons per minute at 1 psi pressure drop. Values calculated from valve laying length, based on derivative of Hazen-Williams equation with surface roughness factor of C=150.

3: 6" valve has lever handle, dimension is from valve stem centerline (not illustrated)

Temperature Pressure Rating

System Operating Temperature °F		73 (23)	100 (38)	110 (43)	120 (49)	130 (54)	140 (60)	150 (66)	160 (71)	170 (77)	180 (82)	190 (88)
Valve Pressure Rating psi (MPa)	PVC	150 (1.03)	93 (.64)	75 (.52)	60 (.41)	45 (.31)	33 (.23)	-0- (-0-)	-0- (-0-)	-0- (-0-)	-0- (-0-)	-0- (-0-)
	CPVC	150 (1.03)	123 (.85)	110 (.76)	98 (.68)	86 (.58)	75 (.52)	68 (.47)	60 (.41)	48 (.33)	38 (.26)	-0- (-0-)

NOT FOR USE WITH COMPRESSED AIR OR GASES



SPEARS® MANUFACTURING COMPANY • CORPORATE OFFICE
 15853 Olden St., Sylmar, CA 91342 • PO Box 9203, Sylmar, CA 91392
 (818) 364-1611 • www.spearsmfg.com

