

# ProAlert®

The Next Big Thing in Liquid Monitoring



### Features

- ✓ High Intensity Red Alarm Light
- ✓ Pulse to Relay Output
- ✓ Super Loud 108dB Audible Alarm
- ✓ Silence Function | Light Remains On
- ✓ Rugged NEMA 4X Industrial Enclosure
- ✓ External Wall Mounting Brackets
- ✓ High Impact Plastic Polycarbonate Shell
- ✓ Includes 6' Power Cord + Watertight Cord
- ✓ Completely Pre-Wired
- ✓ Extra Output Contact to Remote Alarm or PLC

All Plastic  
NEMA 4X  
Enclosure

Built in  
Visual Alarm

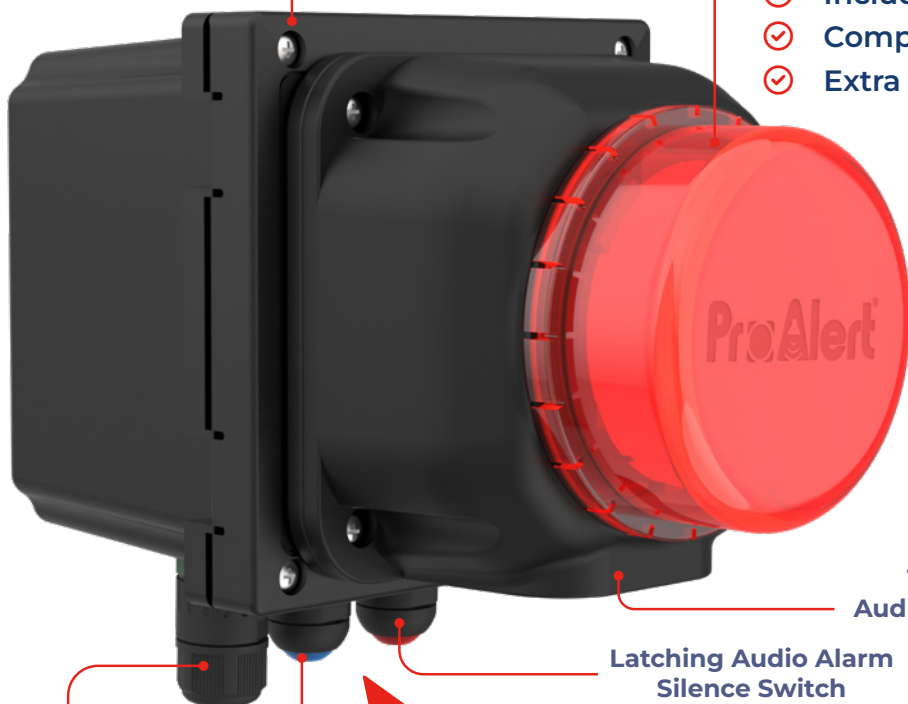

108dB  
Audible Alarm

Latching Audio Alarm  
Silence Switch

Alarm Test

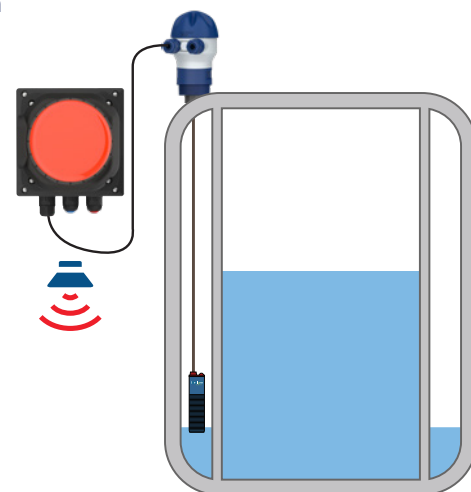
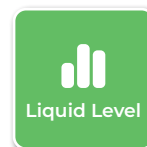

### 3 Easy Mounting Options

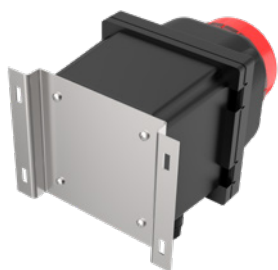

Wall Mount



Panel Mount



Pole/Pipe Mount



# LevelPro® — ProAlert® 2

## Industrial Visual | Audible Sentry Alarm



### Typical Applications

- ✓ High High | Low Level Indication for Tanks | Sumps
- ✓ Bag | Filter Change Out
- ✓ Leak Detection
- ✓ Flow | No Flow Sensors | Pump Protection
- ✓ Upset Condition Notification

### Specifications

- ✓ Dimensions | 7" X 5" X 4.5"
- ✓ Enclosure | NEMA 4X
- ✓ Weight | 2.1 lbs.
- ✓ 24VDC
- ✓ 100 - 240VAC (with DC adapter)

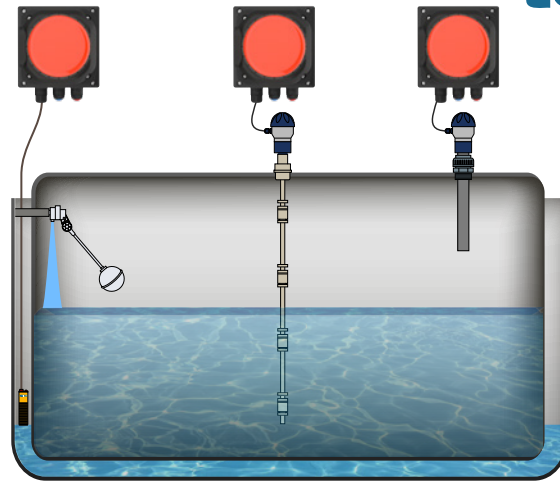

NOTE: The ProAlert® 2 can be used in more than just leak detection applications. It is an excellent high/low level alarm or any other upset condition.

### Model Selection

#### ProAlert® PA223

- PNP | NPN | Dry Contact Input
- Audible | Visual Alarm

#### ProAlert® PA223-PR

- PNP | NPN | Dry Contact Input
- Relay Outputs
- 10A 30VDC | 10A 250VAC | 7A 28VDC | 15A 125VAC
- Audible | Visual Alarm

#### ProAlert® PA223-LD

- PNP | NPN | Dry Contact Input
- Audible | Visual Alarm
- Leak Detection Module for Leak Detection Cable

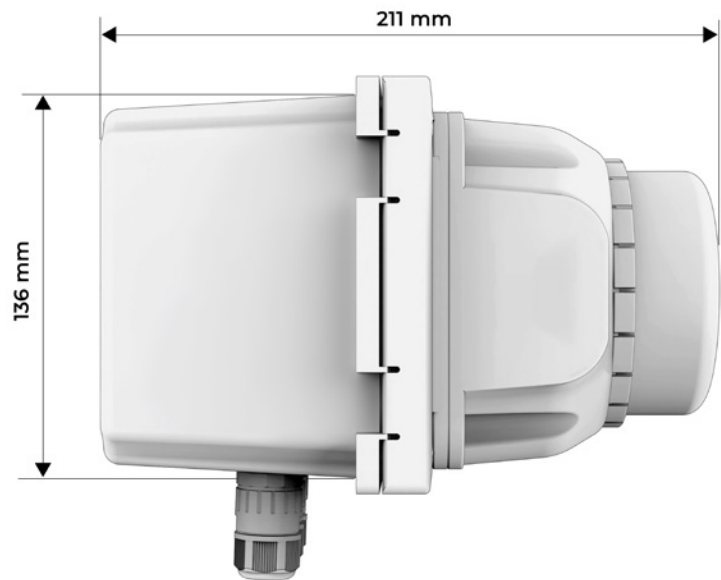

### Wiring Diagram

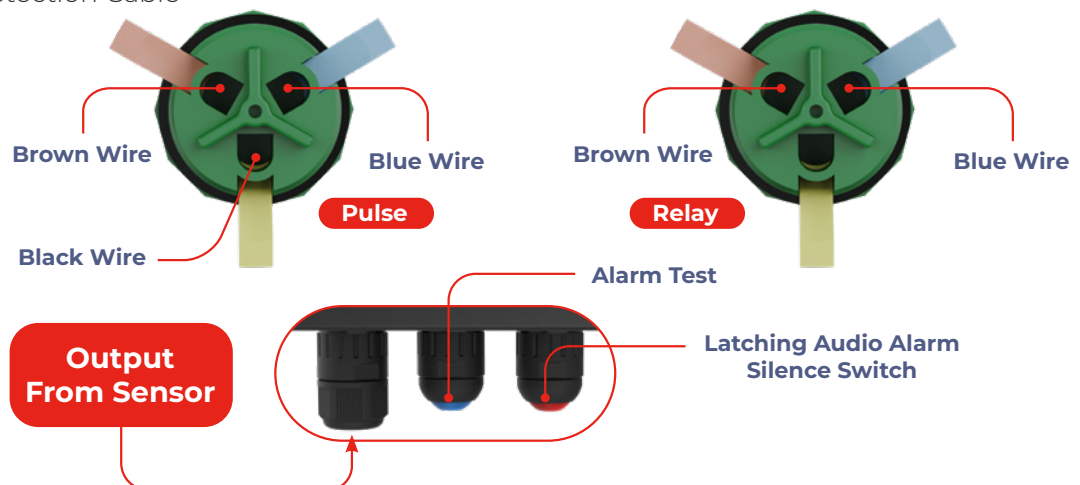
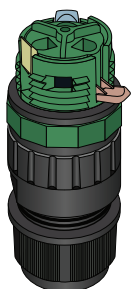

## Wiring Diagram

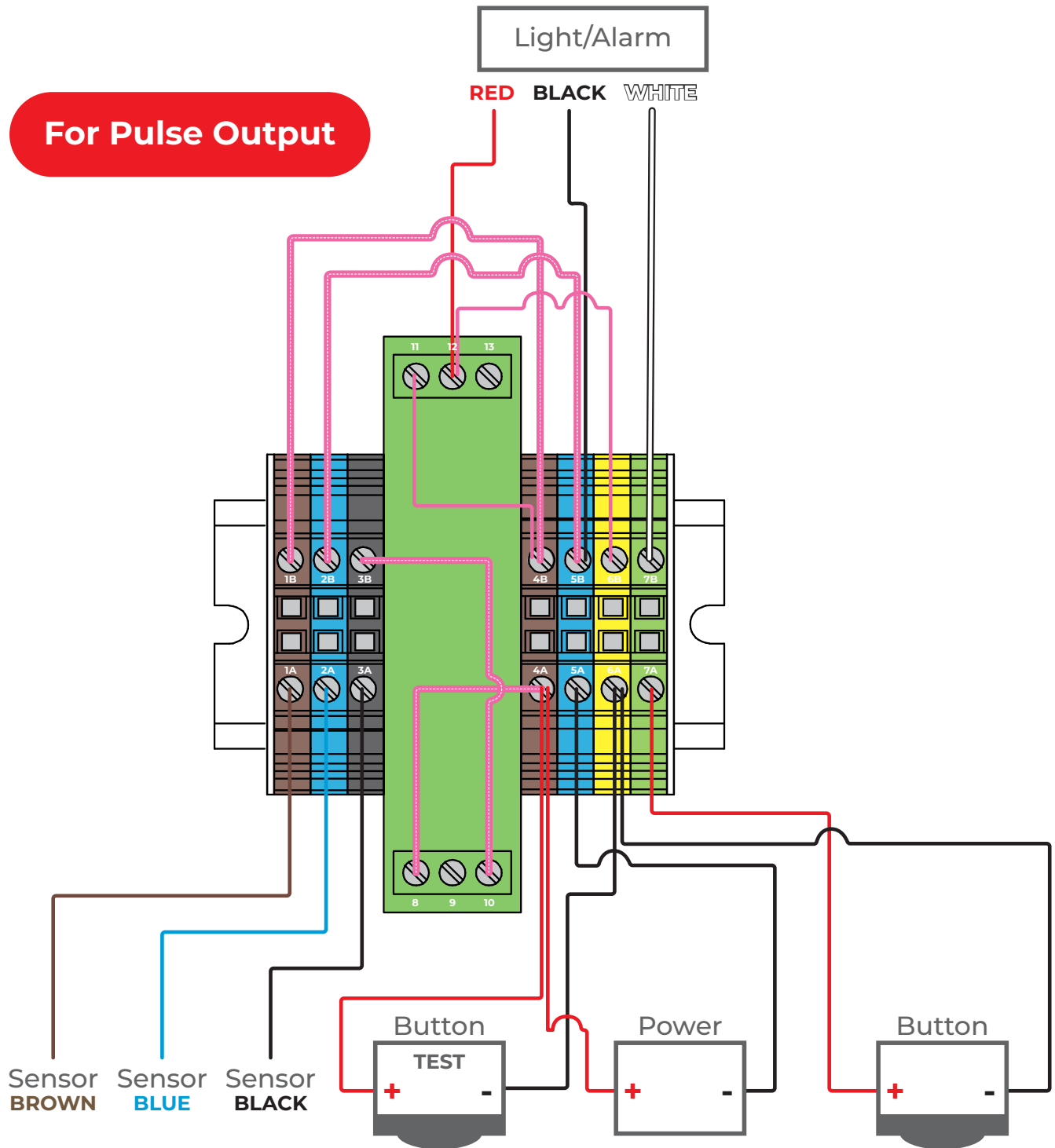

## Wiring Diagram

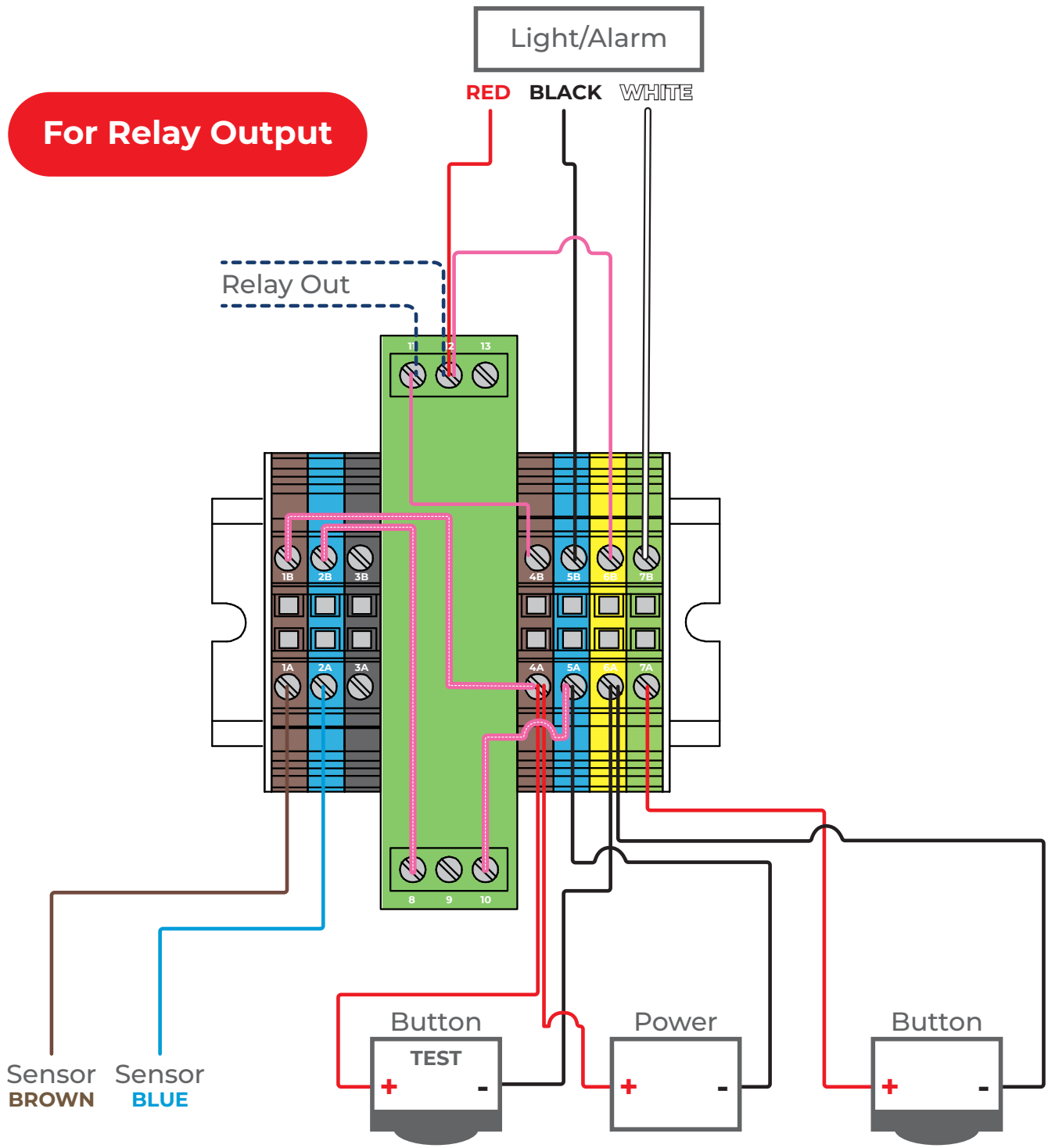

### Wiring Diagram

**For Leak Detection**

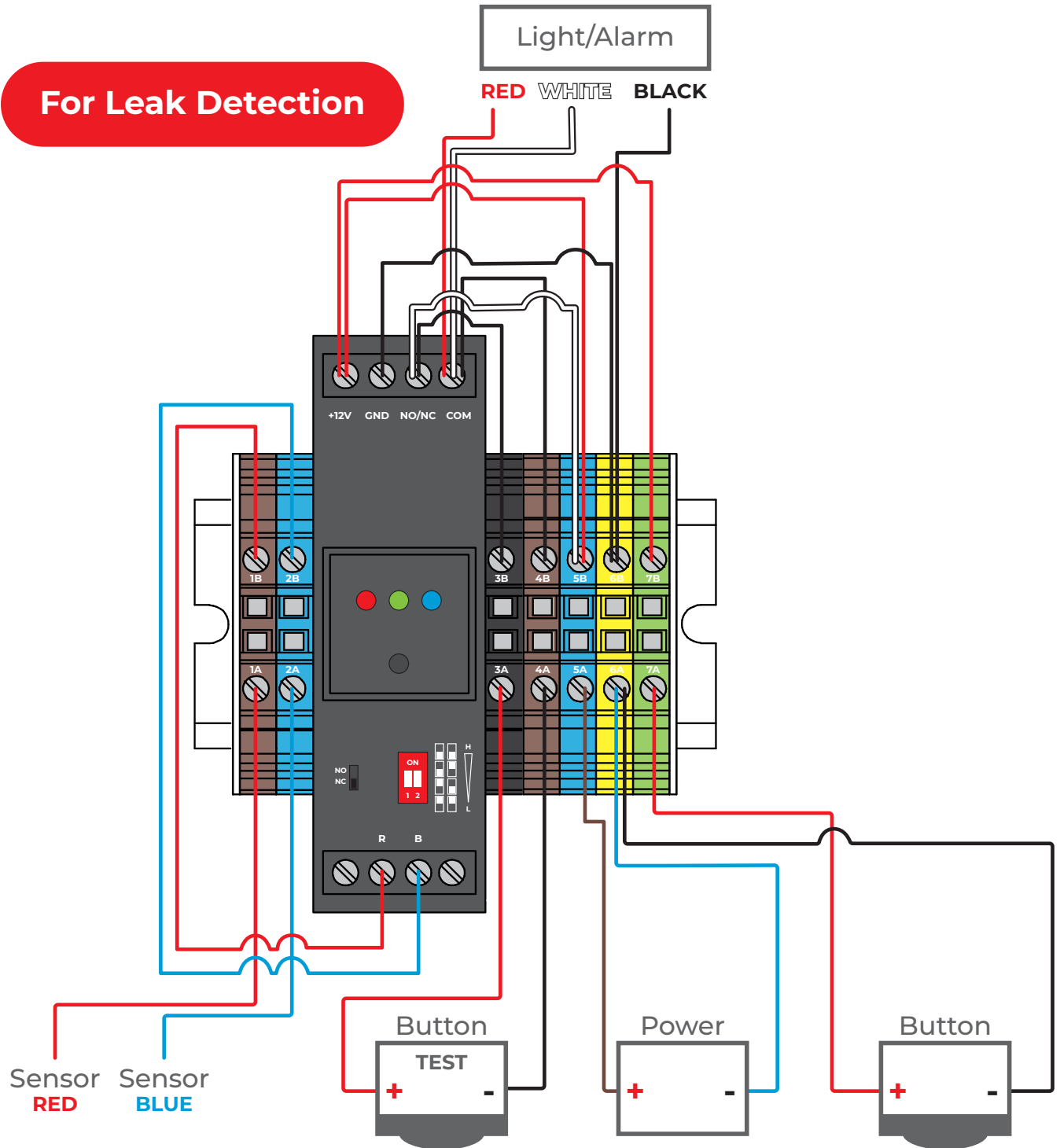



### Setup for LDS-YN Leak Detection

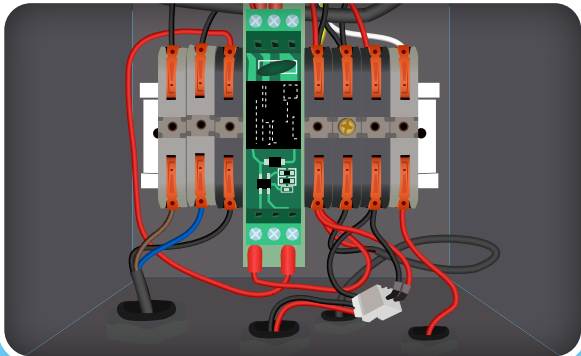

**PRE-WIRED**  
NO INTERNAL WIRING NECESSARY

Inside the Pro-Alert® 2 box, the P2R relay has been prewired to a quick connect which the LDS-YN Leak Sensor will connect to.

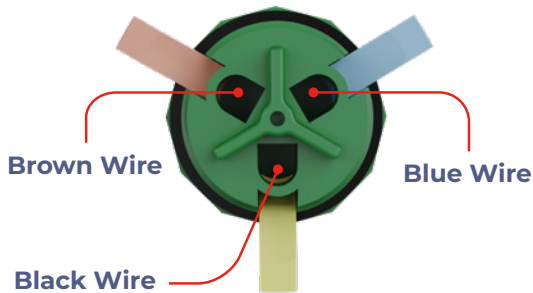

From the LDS-YN Sensor there is a Blue, Black, and Brown wire and they should attach as follows:

- Blue sensor wire will connect to the Blue quick connect terminal.
- Black sensor wire will connect to the Yellow quick connect terminal.
- Brown sensor wire will connect to the Orange quick connect terminal.

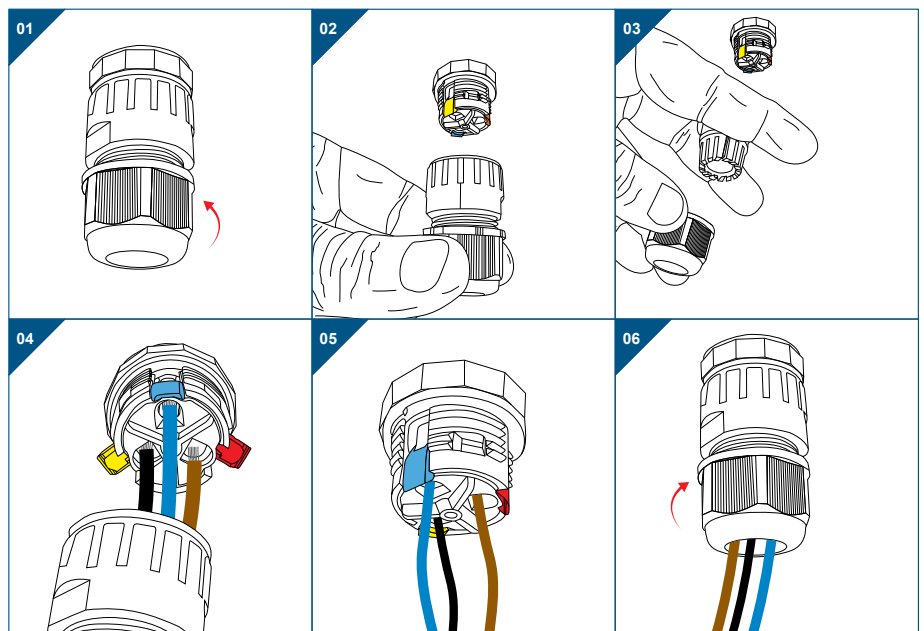

### Troubleshooting:

If the sensor is not working properly follow the following steps:

1. If sensor is in constant state of alarm — Place sensor 4" above a cup of water and turn the potentiometer until the system quits alarming. This will calibrate the sensor to detect a liquid 4" from contact.
2. This unit does not provide a 120v output to run to a PLC/Skada system. It only provides a 12-14v output.

